

Operating Manual

A 4500B Alert/Evacuation Controller and 50 Event Timer

Optional Accessories

- A 2078B Alert/Evac/Cancel Remote Wall Plate (Hard Wired)**
- A 2081 Alert/Evac/Chime/Cancel Remote Wall Plate (Hard Wired)**
- A 4578 Alert/Evac/Cancel Remote Wall Plate (U/UTP Cat5)**
- A 4581 Alert/Evac/Chime/Cancel Remote Wall Plate (U/UTP Cat5)**
- A 4581V Alert/Evac/Chime/Cancel Remote Wall Plate (U/UTP Cat5)**
- A 4564 Emergency Paging Microphone Console (U/UTP Cat5)**



A 2078B Remote Plate



A 2081 Remote Plate



A 4578 Remote Plate



A 4581 Remote Plate

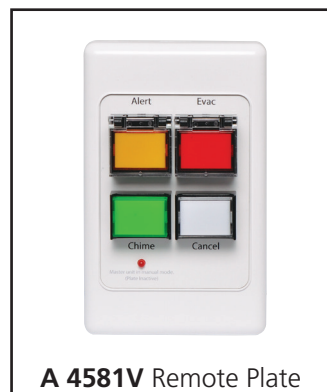

A 4581V Remote Plate



A 4564 Paging Console

User manual revision number: 1.2 07/10/2021

Distributed by Altronic Distributors Pty. Ltd.

Phone: 1300 780 999 Fax: 1300 790 999 Internet: www.altronic.com.au

IMPORTANT NOTE:

Please read these instructions carefully from front to back prior to installation.
They include important setup instructions.
Failure to follow these instructions may prevent the unit from working as designed.



REDBACK is a registered trademark of Altronic Distributors Pty Ltd

You may be surprised to learn that Altronics is still manufacturing hundreds of product lines right here in Australia. We have resisted the move offshore by offering our customers better quality products with innovations to save them time and money.

Our Balcatta production facility manufactures/assembles:

Redback public address products
One-shot speaker & grill combinations
Zip-Rack 19 inch rack frame products

We strive to support local suppliers wherever possible in our supply chain, helping to support Australia's manufacturing industry.

Redback Audio Products

100% developed, designed & assembled in Australia.

Since 1976 we have been manufacturing Redback amplifiers in Perth, Western Australia. With over 40 years experience in the commercial audio industry, we offer consultants, installers and end users reliable products of high build quality with local product support. We believe there is significant added value for customers when purchasing an Australian made Redback amplifier or PA product.

Local support & feedback.

Our best product features come as a direct result of feedback from our customers, and when you call us, you speak to a real person - no recorded messages, call centres or automated push button options.

It's not only the assembly team at Altronics who are employed as a direct result of your purchase, but hundreds more at local companies used in the supply chain.

Industry leading 10 year warranty.

There's a reason we have the industry leading DECADE warranty. It's because of a long tried and tested history of bullet-proof reliability. We've heard PA contractors tell us they still see the original Redford amplifier still in service in schools.

We offer this comprehensive parts & labour warranty on almost every Australian Made Redback public address product. This offers both installers and end users peace of mind that they will receive prompt local servicing in the rare event of any problems.

CONTENTS

	Page
1.0 Overview	
1.1 Introduction	4
1.2 Features	4
1.3 What's in the box	4
1.4 Front panel guide	5
1.5 Rear panel connections	6
2.0 Setup	
2.1 Initial Setup	8
2.2 Alert, Evac and Bell Switches	10
2.3 Programming the timing events using the front buttons	10
2.4 Programming the timing events using the supplied PC software	12
2.5 Setting the current time	16
2.6 Deleting a programmed time	17
2.7 Resetting all programmed times	17
2.8 Setting Alert to Evac Change-Over times	18
2.9 Audio Connections	18
2.10 DIP Switch settings	19
2.11 24V DC Output Connections	19
3.0 Remote Wall Plates	
3.1 A 2078B and A 2081 Remote Plates	20
3.2 A 4578, A 4581 and A 4581V Remote Plates	21
4.0 Paging Console	
4.1 A 4564 Overview	22
4.2 A 4564 DIP Switch Settings	22
4.3 A 4564 Rear Panel Connections	22
5.0 Troubleshooting	
5.1 Symptoms and Remedies	23
5.2 RJ45 Cabling Configuration	23
5.0 Firmware Update	24
6.0 Specifications & Warranty	24

1.0 OVERVIEW

1.1 INTRODUCTION

The A 4500B is a weekly timer and Evacuation controller all housed in a convenient 1RU rack mount chassis. A total of 50 "event" switching times are available through the timing functions. Each event can be set to turn on any single day of the week or on multiple days, from 1 sec up to 24 hours. When a timing event is activated, an MP3 audio file will be played and output through the dual RCA line level output. There are fourteen MP3 playback options for the timing events, which include the Bell, Prebell, Music and folders 5-15. A Micro SD card which is supplied, houses all the MP3 files to be played as well as storing all the timing events (Note: The audio files must be in MP3 format). The timing events can be programmed via the unit's front buttons which is a bit cumbersome, or they can be programmed with the supplied PC software (also available as a download from www.altronics.com.au).

The timing events can also be programmed to activate only a relay with no audio output. This is activated by setting the output to the "relay" option in the programming setup. Once activated the common 24V Out will become active.

The Evacuation controller is designed around industry standard building emergency alert/evacuate requirements. When connected to a paging system amplifier, building occupants can be alerted and/or evacuated in the event of an emergency e.g. fire, gas leak, bomb scare, earthquake. Alert & Evac switches on the front of the unit are fitted with safety covers to prevent accidental operation.

The Alert, Evacuation and Bell tones and the cancel function are triggered by the front switches, or by the rear terminal contacts for remote activation.

The Alert, Evac, Bell and Cancel functions can also be activated via remote plates or the A 4564 Paging Console.

Switched 24V DC Out connections are provided for Bell, Alert, Evac or a Common out. These contacts are for connection of override relays in remote volume controls, warning strobes, bells etc.

The alert and evacuation tones are stored on the Micro SD card (Emergency Tones which conform to AS1670.4 are supplied) to allow the user to provide any tones they require (Note: The audio files must be in MP3 format).

The Evacuation mode has a voice over option for the playback of an evacuation message every third cycle of the evac tone. The voice over message is also stored on the Micro SD card and is DIP switch enabled.

1.2 FEATURES

- MP3 audio format for Bell, Prebell and Music timing outputs
- MP3 audio format Emergency Tones conform to AS 1670.4 (supplied)
- Random play of MP3 files for Prebell and Music triggers
- Easy PC based timing event setup
- Local push button operation of Alert, Evac and Bell
- Remote triggering of Alert, Evac and Bell
- Emergency Paging (Optional via Redback® A 4564)
- MP3 audio format Voice over message (In Evacuation cycle)
- Switched 24VDC output for Bell, Alert or Evac mode
- Pluggable screw terminal connections
- Auxiliary level output
- Battery backup of current time
- 24V DC operation
- Standard 1U 19" rack mount case
- Suitable for any amplifier with an auxiliary input
- 10 Year Warranty
- Australian Designed and Manufactured

1.3 WHAT'S IN THE BOX

A 4500B Alert/Evacuation Controller/24 Hr 7 Day Timer
24V 2A DC Plugpack
Instruction Booklet

1.4 FRONT PANEL GUIDE

Figure 1.4 shows the layout of the A 4500B front panel.

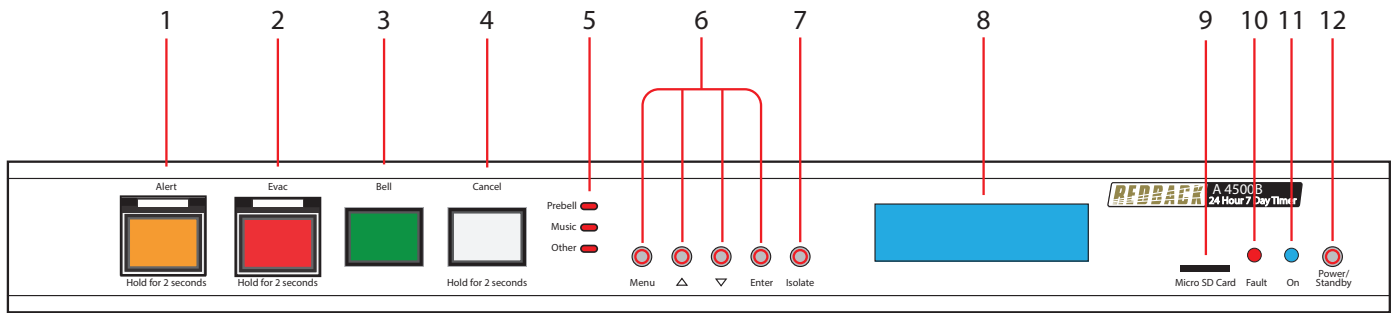

Fig 1.4A

1 Alert Tone Activation Switch

This switch is used to activate the Alert tone. It may need to be pressed for up to 2 seconds to activate.

2 Evac Tone Activation Switch

This switch is used to activate the Evacuation tone. It may need to be pressed for up to 2 seconds to activate.

3 Bell Tone Activation Switch

This switch is used to activate the Bell tone. The LED also indicates when the Bell is active.

4 Cancel Tone Activation Switch

This switch is used to cancel the Alert, Evac or bell tone. It may need to be pressed for up to 2 seconds to activate.

5 Status LEDs

Prebell LED - This LED indicates when the Prebell is active.

Music LED - This LED indicates when an MP3 from the Music Folder is active.

Other LED - This LED indicates when an MP3 from one of the Music Folders 5 - 15 is active.

6 Menu and Navigation Switches

These switches are used to navigate the menu functions of the unit.

7 Isolate Switch

This switch is used to isolate the timing functions of the unit. Note: When this is enabled the Alert, Evac and Chime buttons and remote triggers will still function.

8 LCD Display

This displays the current time and other timing functions.

9 Micro SD Card

This is used to store the MP3 audio files for the Prebell, Bell, Alert, Evac, Music and MP3 folders 5-15 playback. It also stores the timing events for the timer. (More details in section 2.1).

NOTE: All folders except the "Prebell" and "Music" folders must have only one MP3 file installed. The "Prebell" and "Music" folders can have unlimited MP3 files (depending on available storage) and will then randomly play the MP3 files in the folder each time the corresponding prebell or music contact is triggered.

10 Fault Indicator

This LED indicates that the unit has a fault.

11 On Indicator

This LED indicates the unit is ON.

12 Standby Switch

When the unit is in standby mode this switch will illuminate. Press this button to switch the unit ON. Once the unit is ON the On indicator will illuminate. Press this switch again to put the unit back in standby mode.

1.5 REAR PANEL CONNECTIONS

Figure 1.5A shows the layout of the A 4500B rear panel.

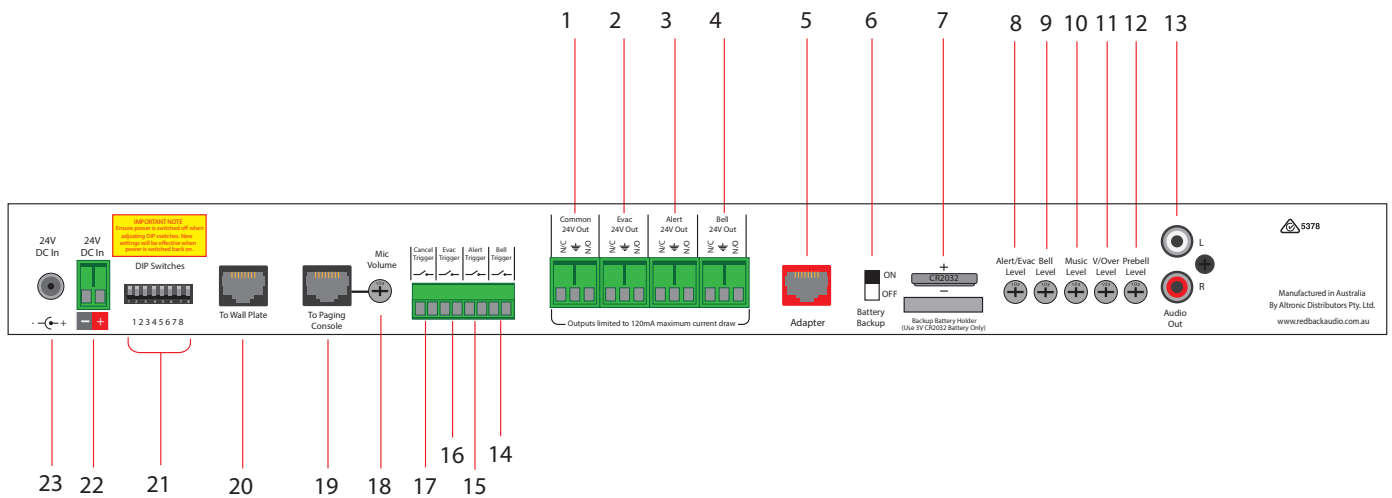

Fig 1.5A

- 1 Common 24V Out**
 This is a common 24V DC output which is activated when any of the Prebell, Bell, Music, Alert or Evac tones are activated. The terminals provided can be used for "Normal" or "Failsafe" modes (see section 2.10 for more details).
- 2 Evac 24V Out**
 This is a 24V DC output which is activated when the Evac tone is activated. The terminals provided can be used for "Normal" or "Failsafe" modes (see section 2.10 for more details).
- 3 Alert 24V Out**
 This is a 24V DC output which is activated when the Alert tone is activated. The terminals provided can be used for "Normal" or "Failsafe" modes (see section 2.10 for more details).
- 4 Bell 24V Out**
 This is a 24V DC output which is activated when the Bell tone or relay only (No MP3 option) is activated. The terminals provided can be used for "Normal" or "Failsafe" modes (see section 2.10 for more details).
- 5 RJ45 Adapter**
 This RJ45 port is for future connection of Redback devices.
- 6 Backup Battery Switch**
 Use this switch to activate the backup battery. (Note: The backup battery only backs up the current time).
- 7 Backup Battery**
 Replace this battery with a 3V CR2032 only. Remove by pulling the battery.
 Note: The positive side of the battery faces upward.
- 8 Alert/Evac Volume**
 Adjust this trimpot to adjust the Alert and Evacuation tones playback volume.
- 9 Bell Volume**
 Adjust this trimpot to adjust the Bell playback volume.
- 10 Music Volume**
 Adjust this trimpot to adjust the Music playback volume.
- 11 Voice-over Volume**
 Adjust this trimpot to adjust the message voice-over playback volume.
- 12 PreBell Volume**
 Adjust this trimpot to adjust the PreBell playback volume.

- 13 Audio Out RCA Connectors**
Connect these outputs to the input of the background music amplifier.

- 14 Bell Contact**
These contacts are for remote triggering of the Bell tone. These could be triggered by a remote switch or other closing contact.

- 15 Alert Contact**
These contacts are for remote triggering of the Alert tone. These could be triggered by a remote switch or other closing contact.

- 16 Evac Contact**
These contacts are for remote triggering of the Evacuation tone. These could be triggered by a remote switch or other closing contact.

- 17 Cancel Contact**
These contacts are for remote triggering of the cancel function. These could be triggered by a remote switch or other closing contact.

- 18 Mic Volume**
Adjust this trimpot to adjust the A 4564 Microphone volume.

- 19 RJ45 interface**
This RJ45 port is for connection to the A 4564 microphone paging console.

- 20 RJ45 interface**
This RJ45 port is for connection to the A 4578, A 4581 and A 4581V wall plates.

- 21 Dip Switches**
These are used to select various options. Refer to DIP Switch Settings section.

- 22 24V DC Input (Backup)**
Connects to a 24V DC backup supply with at least 1 amp current capacity. (Please observe the polarity)

- 23 24V DC input**
Connects to a 24V DC Plugpack with 2.1mm Jack.

2.0 SETUP GUIDE

2.1 INITIAL SETUP

For the unit to function correctly, the supplied Micro SD card must be installed and have MP3 files in each of the Alert, Evac and Bell folders. Figure 2.1 below shows the contents of the Micro SD Card.

NOTE: The unit will display an MP3 error message on the screen if any of the Alert, Evac and Bell folders on the Micro SD card are left empty.

The Micro SD card should have the following folders already installed "Alert, Bell, Evac, Music, Prebell, Voice and 5-15". If these folders don't exist they will have to be created.

Inside each of the Alert and Evac folders there will be a sample MP3 audio file. The alert and evac MP3 files meet the Australian standard for evacuation tones. A library of sample MP3 files is supplied (in the #LIBRARY# folder).

NOTE: All folders except the "Prebell" and "Music" folders must have only one MP3 file installed. The "Prebell" and "Music" folders can have unlimited MP3 files (depending on available storage) and will then randomly play the MP3 files in the folder each time the corresponding prebell or music contact is triggered or time activated.

In order to install MP3 files onto the Micro SD card, or move the sample MP3's to their relevant folders, the Micro SD card will need to be connected to a PC. You will need a PC or laptop equipped with a Micro SD card reader to do this. If a Micro SD slot is not available then the Altronics D 0371B USB Memory Card Reader or similar would be suitable (not supplied).

You will first need to remove power from the A 4500B and then remove the Micro SD card from the front of the unit. To remove the Micro SD card push the card in and it will eject itself.

Step by step guide to install an MP3 into it's associated folder with a Windows based PC.

Step 1: Make sure the PC is on and card reader connected and correctly installed. Then insert the Micro SD card into the reader.

Step 2: Go to "My Computer" or "This PC" and open the Micro SD card which is usually marked "Removable disk". In this case it is named "Removable disk (O:)". Select the removable disk and then you should get a window that looks like figure 2.1.

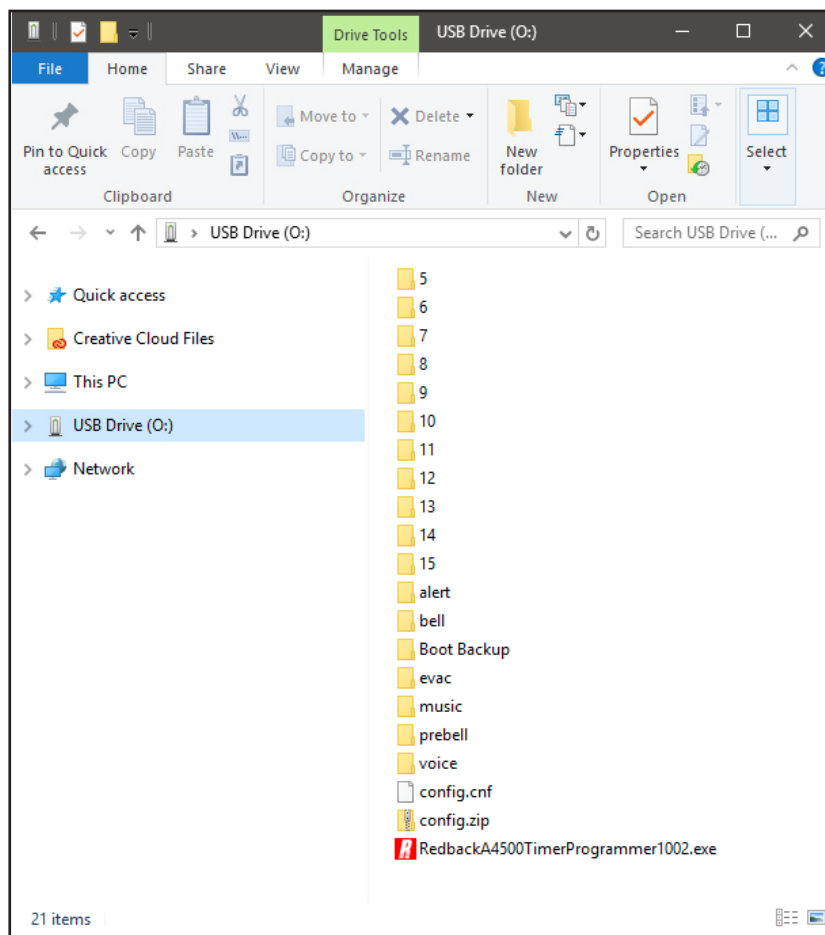

Fig 2.1

Step 3: Open the folder to change, in our example the “bell” folder, and you should get a window that looks like figure 2.2.

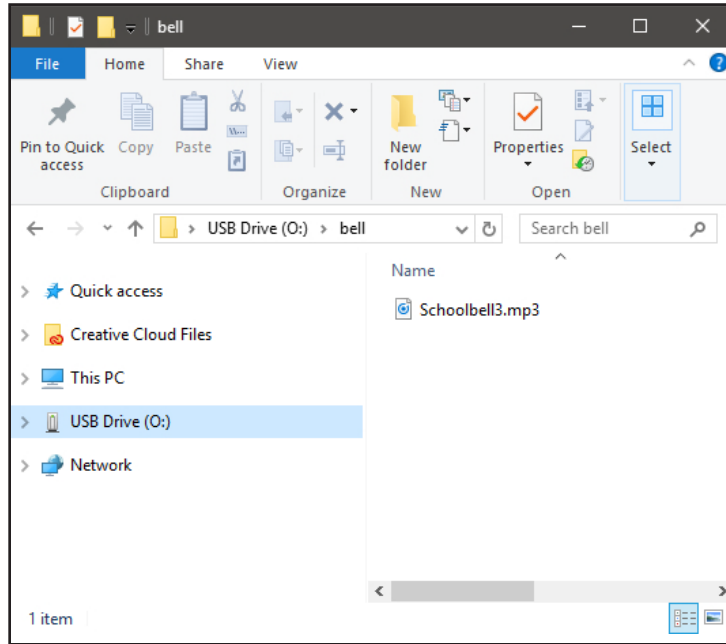

Fig 2.2

Step 4: You should see an MP3 file “Schoolbell3.mp3”. This MP3 file needs to be deleted and replaced by the MP3 file you want to play when you activate the bell. The MP3 file name is not important only that there is one MP3 file (see Note 2) in the “bell” folder. Make sure you delete the old MP3!

Note 1: MP3 files should have the following minimum specifications for optimum performance.

128kbps, 44.1kHz, 32bit, VBR or CBR, Stereo (even better as mono).

Note 2: All folders except the “Prebell” and “Music” folders must have only one MP3 file installed. The “Prebell” and “Music” folders can have unlimited MP3 files (depending on available storage).

Note that the new MP3 file cannot be “Read only”. To check this, right click on the MP3 file and scroll down and select Properties, you will get a window that looks like figure 2.3. Make sure the “Read Only” box has no tick in it.

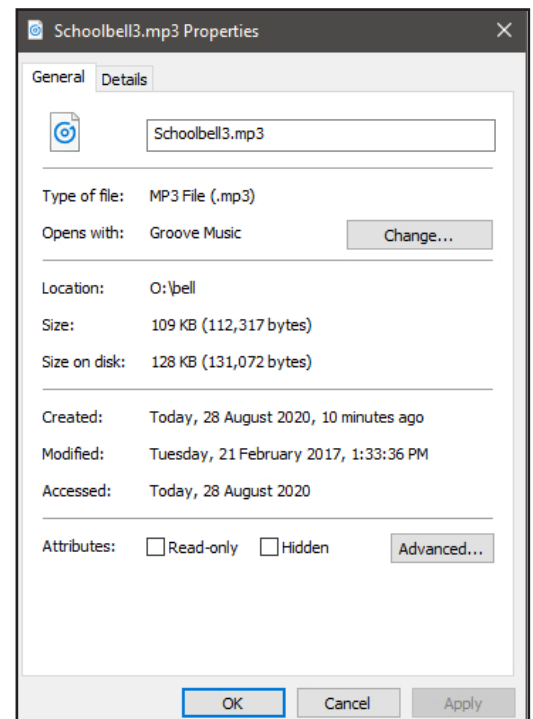

Fig 2.3

Repeat these steps for the other folders.

The new MP3's are now installed on the Micro SD card, and the card can be removed from the PC following windows safe card removal procedures. Make sure the A 4500B is OFF and insert the Micro SD card into the Micro SD card slot ; it will click when fully inserted.

The A 4500B can now be switched back On. If all the MP3 files are OK then the unit will display the time screen. If an MP3 error message is displayed, there is a problem with one or more of the MP3 files.

2.2 ALERT, EVAC AND BELL SWITCHES

The Alert, Evac and Bell switches on the front of the unit all work in momentary mode. ie. The alert tone will continue to sound after the alert switch is momentarily pressed and the evac tone will continue to sound after the evac switch is momentarily pressed. There is an automatic alert to evac switch-over option associated with the front panel switches (refer to section 2.8).

Note 1: The tone that is being sounded (ie alert, evac, bell) will be indicated by the illumination of the relevant front panel indicator.

Note 2: To cancel a tone either use the remote cancel contacts or the front cancel button. Note the cancel button will need to be depressed for 2 seconds. This is to prevent accidental cancelling of a tone.

The Alert, Evac and Bell tones are stored on the supplied Micro SD card. Separate folders are supplied on the Micro SD card for each tone. It is up to the user to provide the MP3 files (they must be in MP3 format) for each of the tones. A library of sample MP3 files is supplied (in the #LIBRARY# folder). See section 2.1 for more details.

NOTE: The unit will display an MP3 error message on the screen if any of the folders on the Micro SD card are left empty. I.e. the Alert, Bell, Evac, Music, Prebell and Voice folders must all have an MP3 file inside.

Once these Alert, Evac and Bell outputs are activated, the corresponding 24V switched outputs will become active (refer to section 2.6 for more details)

2.3 PROGRAMMING THE TIMING EVENTS USING THE FRONT BUTTONS

If the unit starts up correctly and no error messages are displayed, the model number will be displayed briefly before the current time is shown. See Fig 2.4.



Altronics A 4500
EVACUATION TIMER

Fig 2.4

If this screen doesn't appear and instead an MP3 error message is displayed, then either the Micro SD card is not inserted correctly or there is a missing MP3 file.

NOTE: The unit will display an MP3 error message on the screen if any of the folders on the Micro SD card are left empty. I.e. the Alert, Bell, Evac, Music, Prebell and Voice folders must all have an MP3 file inside.

The main screen (Current Time Screen) shown in Fig 2.5 displays the current time and day, and the next programmed event.

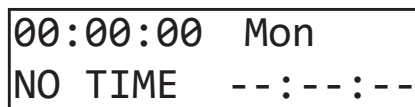

00:00:00 Mon
NO TIME --:--:--

Fig 2.5

When this screen is displayed the unit is running in "AUTO MODE" and therefore all outputs will work as programmed. However if the unit is in any of the sub menu's (Menu Mode) the unit will no longer respond to any event that has been programmed to occur. On exiting the menu, the timer will check all programmed events and update the status of the output zones.

In order to set up the timer, the station (or event) times will need to be programmed. This can be achieved by using the buttons on the front of the unit or via the PC software (supplied on the Micro SD card) see section 2.4 for more details.

PROGRAMMING THE TIMING EVENTS USING THE FRONT BUTTONS

There are five buttons on the front of the timer which are used to program the unit and navigate the various menus.

SPECIAL NOTE ABOUT "AUTO MODE" OPERATION

If the timer is not displaying the main clock screen, where the time is changing, the unit is not running in "Auto Mode". This means it will not be checking any of the programmed events and hence will not activate any outputs automatically.

Essentially this means that as soon as the Menu button is pressed the unit is no longer in "Auto Mode". Make sure to return to the main screen by exiting all menu's when not making changes.

Press the “Menu” button on the front of the timer. The unit is now in “Menu Mode” and the screen should display the “Times Adjust” Screen. This is the first of 5 sub menu screens which are navigated by pressing the up and down buttons as shown in Fig 3.1. Pressing the Menu button again will exit the menu structure and return the user to the Main Screen.

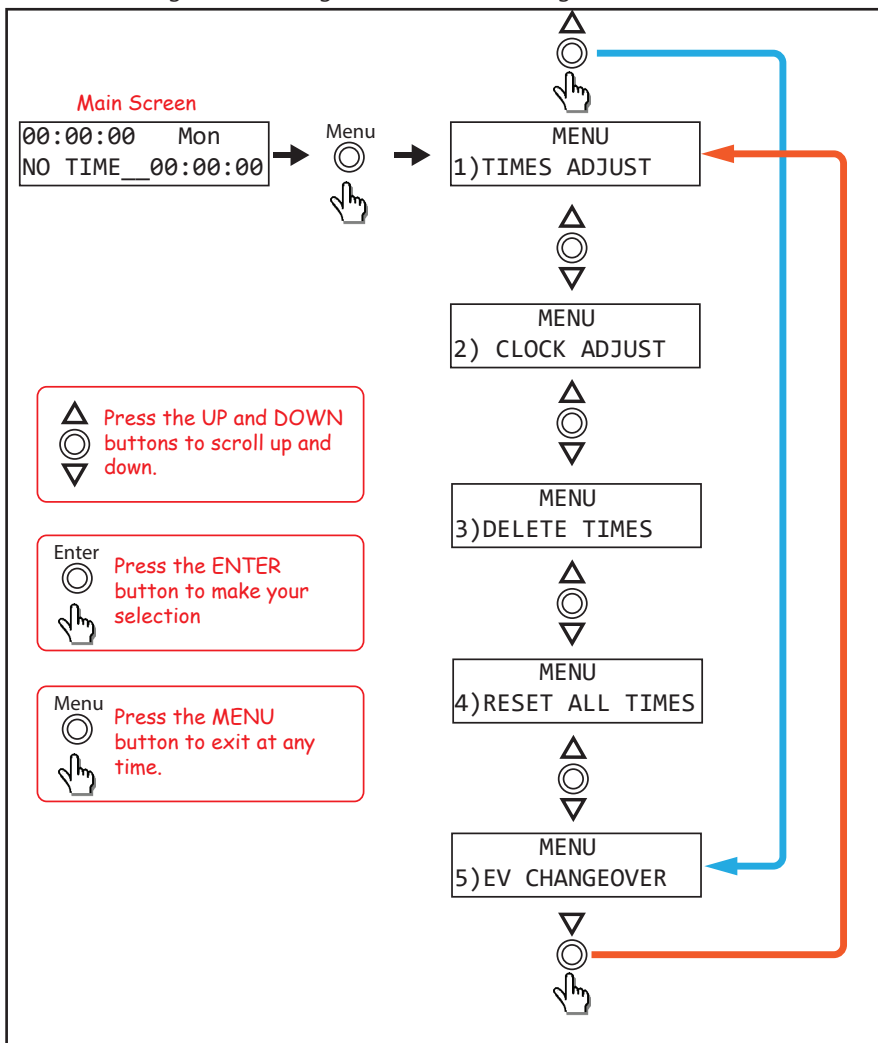

Select the desired sub menu by pressing the “Enter” button.

There are 4 options to choose from.

- 1) Times Ajdust
- 2) Clock Adjust
- 3) Delete Times
- 4) Reset All Times
- 5) EV Changeover

Fig 2.6

2.3.1 Times Adjust

After selecting this option, the screen as shown in Fig 2.7 should appear.

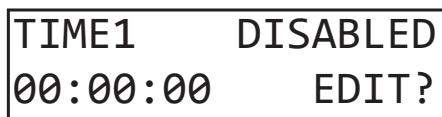

Fig 2.7

This option allows the user to enter the Station (Event) information which includes the event “Turn on time”, “Period” and “Output MP3”.

The top left text is the time event number. Up to 50 events can be programmed into the A 4500B. Pressing the “up” and “down” buttons at this stage will move up and down through the events 1- 50. The top right text indicates that TIME1 (Event1) is currently disabled. The bottom left text refers to the time this event will happen (i.e. the “Start” Time).

Press the “Enter” button to edit this event, or press the “Menu” button to exit.

Pressing the Enter button will take you to the “Editing Time” screen (Refer to fig 2.8). This is where the event “Start” time is entered. The cursor will be positioned over the hour section of the time. Use the up and down buttons to change the

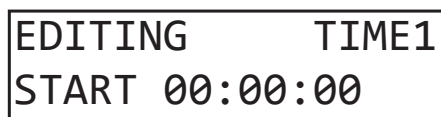

Fig 2.8

hour and then press the “Enter Button” to confirm the hour. The cursor will move to the minutes section of the time. Use the up and down buttons to change the minutes and then repeat the process again for the seconds. Once the seconds have been updated the screen will change to the “Period” set screen (Refer to fig 2.9) . This is where the length of time the event should occur, is recorded.

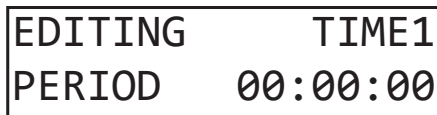

Fig 2.9

Once again, use the up and down buttons to set the hour, minutes and seconds and press enter when finished. Once the period has been set, the desired output MP3 for this event is to be set using the MP3 output screen (See fig 2.10).

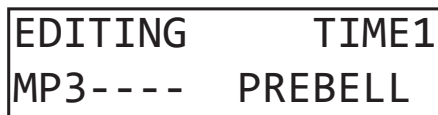

Fig 2.10

The MP3 output defaults to Prebell. Scroll through the other options by using the up and down buttons. The MP3 output can be set to Prebell, Bell, Music, No MP3 or the output can be disabled. These MP3 outputs correspond to the MP3 audio files located in the Prebell, Bell and Music folders on the Micro SD card.

RELAY OUTPUT CONFIGURATION

The 24V switched outputs associated with the Prebell, Bell and Music folders are as follows.
 When the Bell output is active the Bell 24V output and Common 24V output will become active.
 When the Prebell and Music outputs are active the the Common 24V output only will become active.
 The NO MP3 option will activate the Bell and Common 24V output, but no audio file will be played.

Once the desired output for the event has been set, press the enter button to move to the next screen (See fig 2.11). This is where the days of the week this event will occur are entered. The top right line of text refers to the days of the week, Monday through to Sunday. The line of text below this sets each day "ON" or "OFF". Use the up and down buttons to set the day to Y for "ON" and N for "OFF".



Fig 2.11

Once the days of the week are set, press the enter button to confirm and be returned to the main menu. Repeat this process for any other events to be programmed.
 This process of entering the events can be quite time consuming. An easier method of entering this information is by using the supplied PC software which is provided on the Micro SD card (see section 2.4).

2.4 PROGRAMMING THE TIMING EVENTS USING THE SUPPLIED PC SOFTWARE

The PC software is provided on the units' Micro SD Card and is called "RedbackA4500TimerProgrammer".

In order to access the program, the Micro SD card will need to be connected to a PC. You will need a PC or laptop equipped with an Micro SD card reader to do this. If an Micro SD slot is not available then the Altronics D 0371B USB Memory Card Reader or similar would be suitable (not supplied).

You will first need to remove power from the A 4500B and then remove the Micro SD card from the rear of the unit. To remove the Micro SD card push the card in and it will eject itself.

Make sure the PC is on and card reader connected and correctly installed. Then insert the Micro SD card into the reader.

Go to "My Computer" or "This PC" and open the Micro SD card which is usually marked "Removable disk". In this case it is named "Removable disk (F:)". Select the removable disk and then you should get a window that looks like figure 2.12.

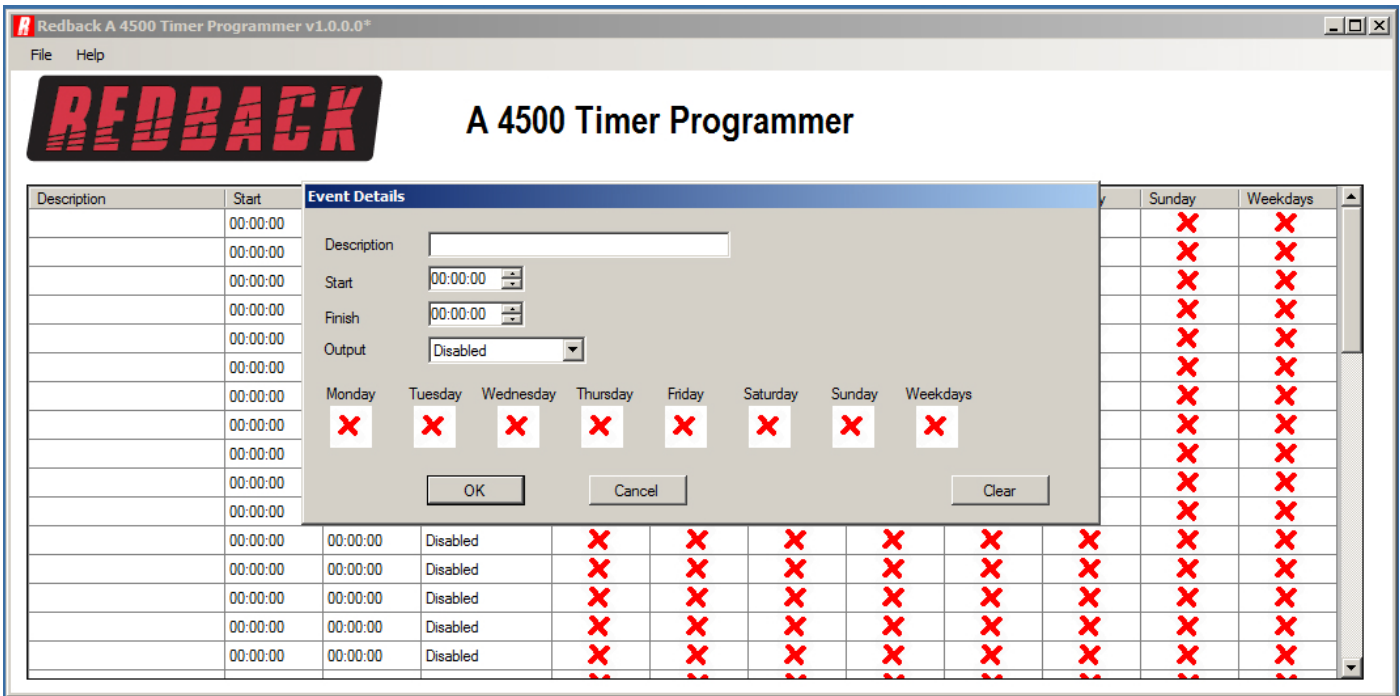

Fig 2.14

An event can now be programmed from this window. A description of the event can be added if desired such as Pre bell, Morning Tea etc. The start time, finish time, output and days of the week can all be entered. Selecting the days of the week is as simple as clicking the desired days or selecting the weekdays box.

The latest PC software now includes up to fourteen MP3 output folders, which include Bell, Prebell, Music and output folders 5 - 15. The "Relay Only" Output option only activates the Bell 24V DC output (see section 2.11).

NOTE: All folders except the "Prebell" and "Music" folders must have only one MP3 file installed. The "Prebell" and "Music" folders can have unlimited MP3 files (depending on available storage) and will then randomly play the MP3 files in the folder each time the corresponding prebell or music contact is triggered or time activated.

Figure 2.14 shown below illustrates an example. This event is the prebell for a primary school and is programmed to activate 5 minutes before the first bell of the day.

A music track will be played at 8:55:00 and continue to play until 08:59:59.

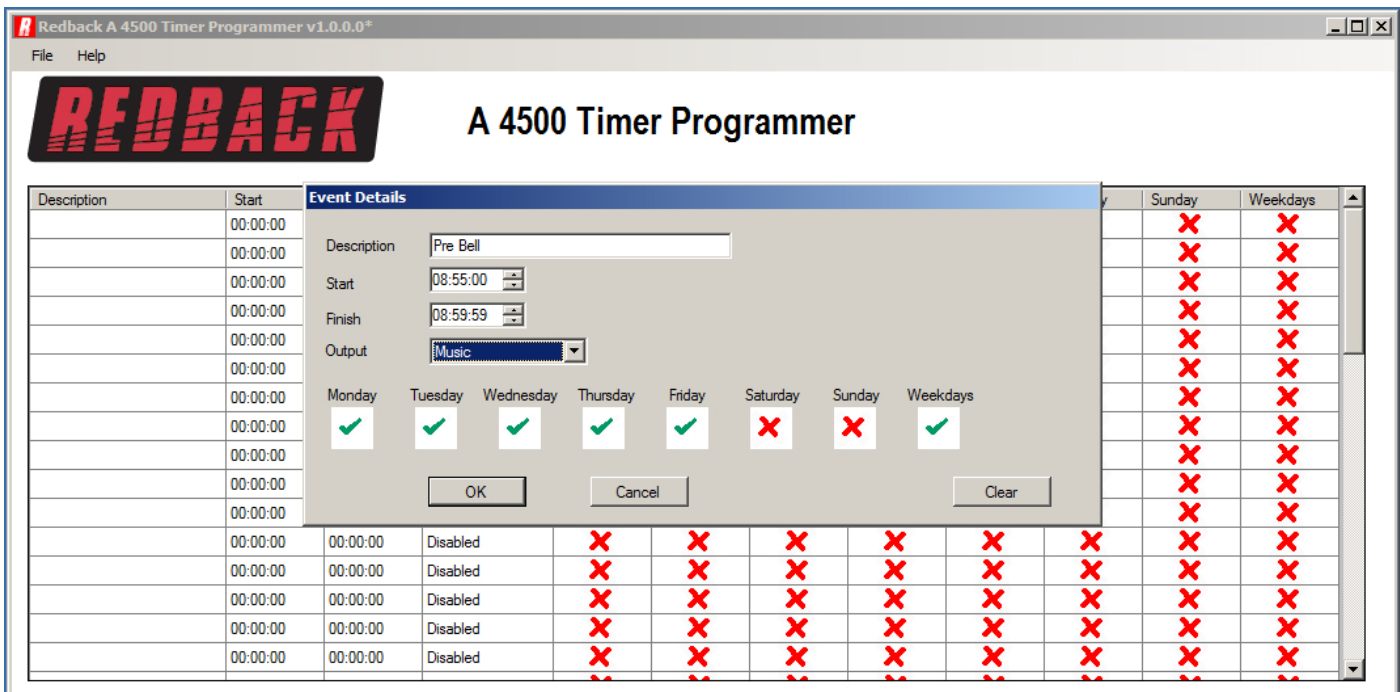

Fig 2.15

The event should now appear in the programming window as shown in fig 2.16.

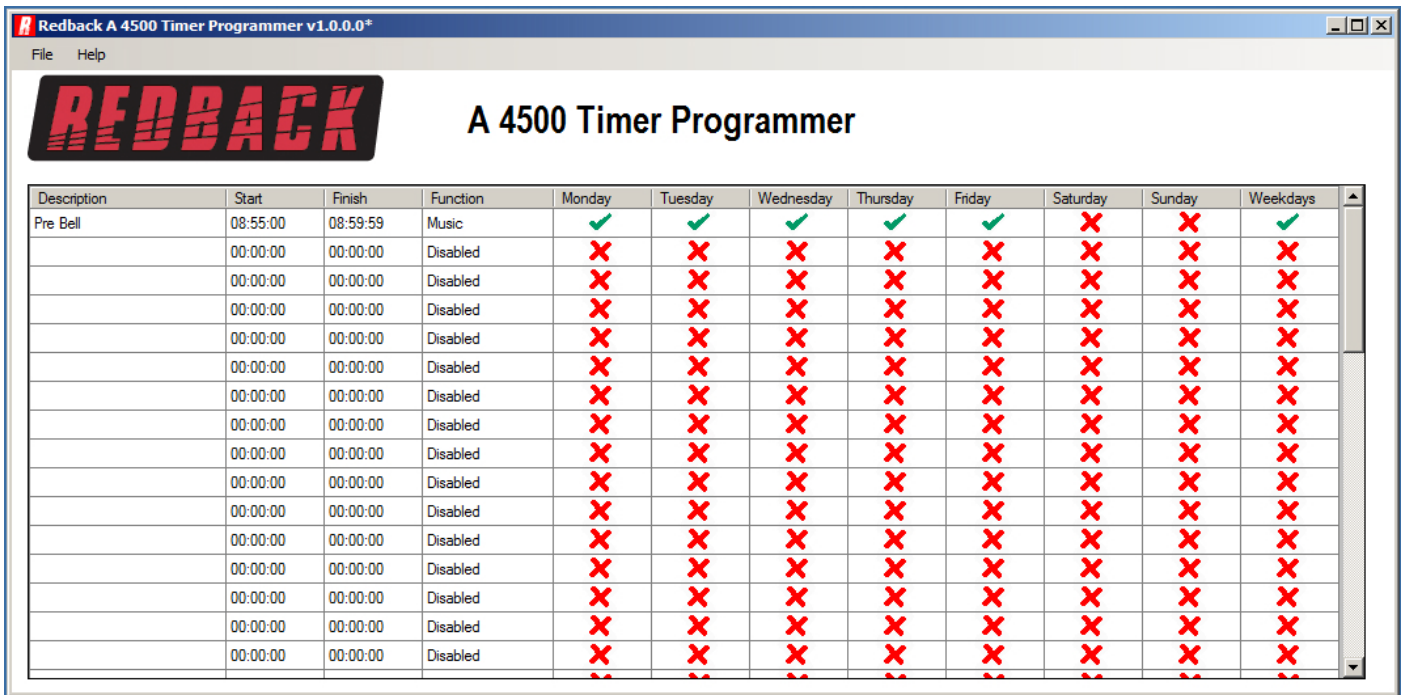

Fig 2.16

Another event is now added by following the same steps. Double click on a blank line and then enter the details required as illustrated in fig 2.17. This is the first bell of the day for the primary school.

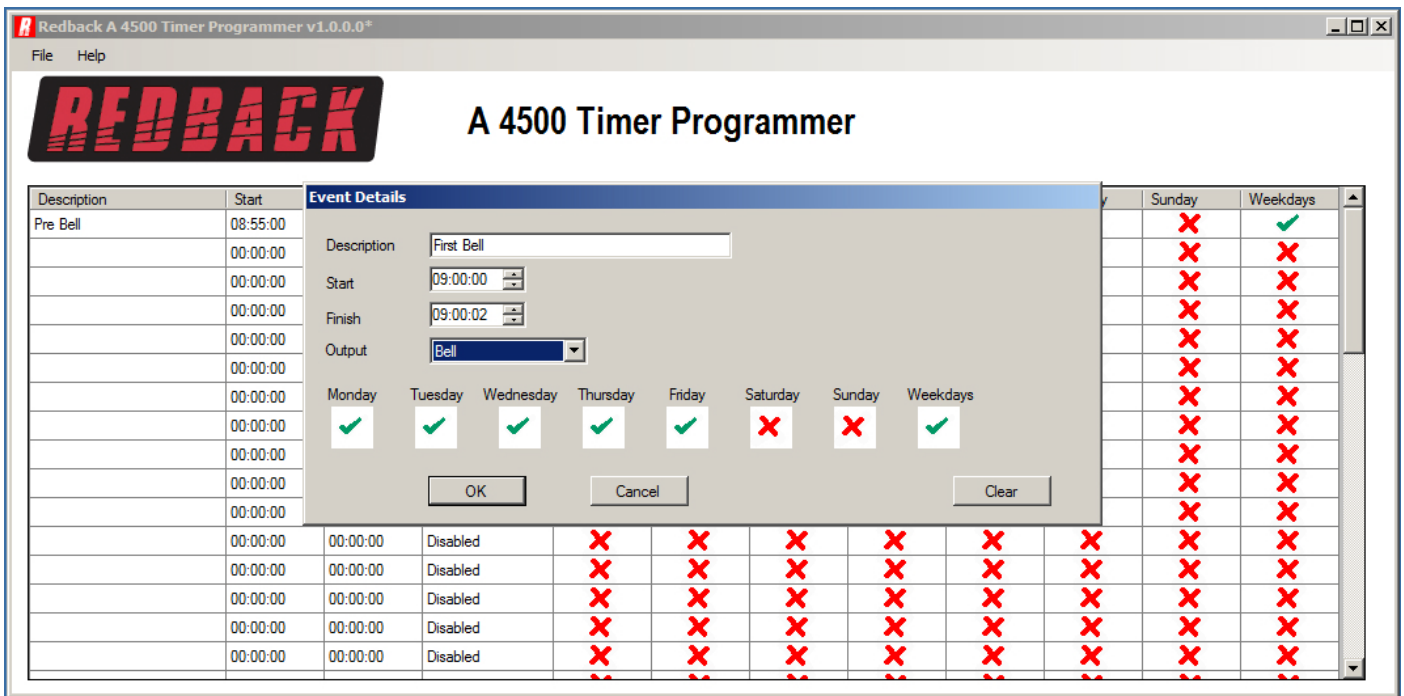

Fig 2.17

Press the OK button and the second event now appears in the programming screen as shown in fig 2.18.

Description	Start	Finish	Function	Monday	Tuesday	Wednesday	Thursday	Friday	Saturday	Sunday	Weekdays
Pre Bell	08:55:00	08:59:59	Music	✓	✓	✓	✓	✓	✗	✗	✓
First Bell	09:00:00	09:00:02	Bell	✓	✓	✓	✓	✓	✗	✗	✓
	00:00:00	00:00:00	Disabled	✗	✗	✗	✗	✗	✗	✗	✗
	00:00:00	00:00:00	Disabled	✗	✗	✗	✗	✗	✗	✗	✗
	00:00:00	00:00:00	Disabled	✗	✗	✗	✗	✗	✗	✗	✗
	00:00:00	00:00:00	Disabled	✗	✗	✗	✗	✗	✗	✗	✗
	00:00:00	00:00:00	Disabled	✗	✗	✗	✗	✗	✗	✗	✗
	00:00:00	00:00:00	Disabled	✗	✗	✗	✗	✗	✗	✗	✗
	00:00:00	00:00:00	Disabled	✗	✗	✗	✗	✗	✗	✗	✗
	00:00:00	00:00:00	Disabled	✗	✗	✗	✗	✗	✗	✗	✗
	00:00:00	00:00:00	Disabled	✗	✗	✗	✗	✗	✗	✗	✗
	00:00:00	00:00:00	Disabled	✗	✗	✗	✗	✗	✗	✗	✗
	00:00:00	00:00:00	Disabled	✗	✗	✗	✗	✗	✗	✗	✗
	00:00:00	00:00:00	Disabled	✗	✗	✗	✗	✗	✗	✗	✗
	00:00:00	00:00:00	Disabled	✗	✗	✗	✗	✗	✗	✗	✗
	00:00:00	00:00:00	Disabled	✗	✗	✗	✗	✗	✗	✗	✗

Fig 2.18

As the events are added they will be listed in chronological order. (I.e. In time order). If a new event was programmed, to start at 08:45:00 for instance, this new event would appear before the prebell event. Continue to enter the events in this manner and then save the program by clicking file and then save as. The file must be saved as config.cnf on the Micro SD card in place of the file already on the Micro SD card.

With the events now programmed on the Micro SD card, the card can be removed from the PC following windows safe card removal procedures. Make sure the A 4500B is OFF and insert the Micro SD card into the slot in the front; it will click when fully inserted.

The A 4500B can now be switched back On. If all is well, after the startup screen is displayed the current time and next event should be displayed on the screen.

2.5 SETTING THE CURRENT TIME

Press the “Menu” button on the front of the timer. The unit is now in “Menu Mode” and the screen should display the “Times Adjust” Screen. This is the first of 5 sub menu screens which are navigated by pressing the up and down buttons as shown in Fig 2.19. Pressing the Menu button again will exit the menu structure and return the user to the Main Screen.

Select the CLOCK ADJUST sub menu.

After selecting this option, the screen as shown in Fig 2.20 should appear.

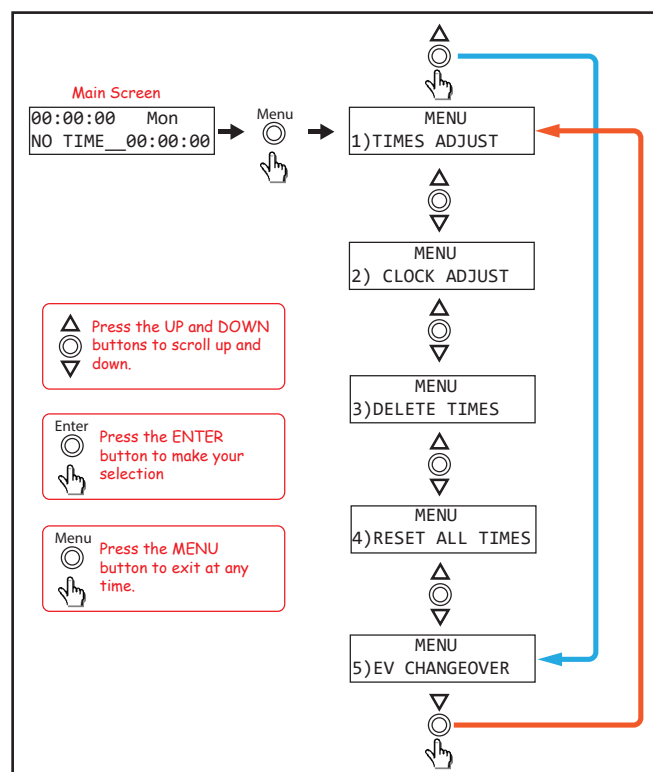

Fig 2.19

EDITING CLOCK 00:00:00 Mon

Fig 2.20

The cursor will be positioned over the hour section of the time. Use the up and down buttons to change the hour and then press the "Enter Button" to confirm the hour. The cursor will move to the minutes section of the time. Use the up and down buttons to change the minutes and then repeat the process again for the seconds. Once the seconds have been updated the cursor will move to the day of the week. Use the up and down buttons again to change the day and then press enter to confirm. The time is now set.

2.6 DELETING A PROGRAMMED TIME

Press the "Menu" button on the front of the timer. The unit is now in "Menu Mode" and the screen should display the "Times Adjust" Screen. This is the first of 5 sub menu screens which are navigated by pressing the up and down buttons as shown in Fig 2.19. Pressing the Menu button again will exit the menu structure and return the user to the Main Screen.

Select the DELETE TIMES sub menu.

After selecting this option, the screen as shown in Fig 2.21 should appear.

TIME1 PREBELL 07:55:00 DELETE?

Fig 2.21

From this point the "Up" and "Down" buttons can be used to scroll through the different times, or press the "Enter" button to delete this time. After deleting the time, a message will indicate that the time has been cleared and the next time will then be displayed on the screen. Press "Enter" to delete, "Menu" to exit or the "Up" and "Down" buttons to scroll to another time.

A time can also be deleted using the PC software.

See section 2.4 for instructions regarding accessing the event programming. A time can be removed by double clicking on the required programmed line and then pressing the "CLEAR" button.

2.7 RESET ALL PROGRAMMED TIMES

Press the "Menu" button on the front of the timer. The unit is now in "Menu Mode" and the screen should display the "Times Adjust" Screen. This is the first of 5 sub menu screens which are navigated by pressing the up and down buttons as shown in Fig 2.19. Pressing the Menu button again will exit the menu structure and return the user to the Main Screen.

Select the RESET ALL TIMES sub menu.

After selecting this option, the screen as shown in Fig 2.22 should appear.

RESET ALL TIMES UP=YES / DN = NO

Fig 2.22

Press the "UP" button to reset all the times programmed and stored on the Micro SD card. Press the "No" button to exit without resetting the times.

2.8 EV CHANGEOVER

Press the “Menu” button on the front of the timer. The unit is now in “Menu Mode” and the screen should display the “Times Adjust” Screen. This is the first of 5 sub menu screens which are navigated by pressing the up and down buttons as shown in Fig 2.19. Pressing the Menu button again will exit the menu structure and return the user to the Main Screen.

Select the EV CHANGEOVER sub menu.

After selecting this option, the screen as shown in Fig 2.23 should appear.



The image shows a rectangular box with a black border. Inside the box, the text "EVAC CHANGEOVER" is displayed on the top line, and "0 SECONDS" is displayed on the bottom line. The text is in a bold, sans-serif font.

Fig 2.23

This option allows the user to enter the automatic switch over time between the Alert and Evac cycles.

NOTE: This affects the front panel Alert and Evac buttons and the rear Alert and Evac contacts.

Press the “UP” and “DOWN” buttons to scroll through the various times available and press enter when the desired switch-over time is highlighted. The changeover times go up in 10 second intervals up to 600 seconds.

NOTE: If the changeover time is set to “0” the changeover will be de-activated and therefore the unit will not switch over from the Alert cycle to the Evac cycle automatically.

2.9 AUDIO CONNECTIONS

Audio Output:

This output consists of stereo RCA sockets with an output of 0dBm into a 600Ω input. This is suitable for most PA amplifier auxiliary inputs.

Rear Panel Volume Controls:

The output levels of the Alert/Evac, Prebell, Bell, Music and Voice Over tones can all be adjusted via trimpots located on the rear of the unit.

2.10 DIP SWITCH SETTINGS

The A 4500B has various options which are set by the DIP switches on the rear of the unit. These are outlined below and in figures 2.24 and 2.25.

IMPORTANT NOTE:
 Ensure power is switched off when adjusting DIP switches.
 New settings will be effective when power is switched back on.

Switch 1

This switch is used to either loop the Bell/Prebell, or play the Bell/Prebell only once after it has been triggered.

ON = Loop, OFF = Play Once

Switch 2

DIP switch 2 enables or disables the voice over message. The voice-over message is played in between every three cycles of the evac tone.

ON = Enabled, OFF = Disabled

Switch 3

This switch can be used to lockout the menu button, to deter tampering with the programmed times.

ON = Menu button disabled, OFF = Menu button enabled

Switch 4

This switch can be used to lockout the front isolate button.

ON = Isolate button disabled, OFF = Isolate button enabled

Switch 5-8 Not Used

DIP SWITCH SETTINGS					
SW	ON	OFF	SW	ON	OFF
1	Loop PreBell/Bell Until Cancelled	Play Prebell/Bell Once	2	Voice Over Enabled	Voice Over Disabled
3	Disable Menu Options	Enable Menu Options	4	Disable Isolate Switch	Enable Isolate Switch
5-8	NOT USED				

Fig 2.24

2.11 24V OUTPUT CONNECTIONS

These contacts can be used for connection of override relays in remote volume controls, or strobes for unusually noisy environments. An override relay is necessary where attenuators are used so that the alert tone, evac tone or message is broadcast at full volume regardless of the volume setting on the individual volume control (attenuator).

Alert/Evac 24V Out:

These contacts are for switched 24V outputs whenever the alert or evac tones are activated. These may be used to run external systems such as strobes in unusually noisy environments, or override relays in remote volume controls.

When this output becomes active, 24V will appear between the N/O contact and the GND contact. When this output is not active 24V will appear between the N/C contact and the GND.

Bell 24V Out:

These contacts are for switched 24V outputs whenever the Bell or Relay Only (No MP3 option) are activated. These contacts are for operating an external relay used to operate something like a lunch bell etc.

When this output becomes active, 24V will appear between the N/O contact and the GND contact. When this output is not active 24V will appear between the N/C contact and the GND.

Common 24V Out:

These contacts are for switched 24V outputs whenever the Alert, Evac, Bell, Prebell or Relay Only (No MP3 option) tones are activated. When this output becomes active, 24V will appear between the N/O contact and the GND contact. When this output is not active 24V will appear between the N/C contact and the GND.

3.0 REMOTE WALL PLATES

There are a number of remote wall plates which can be connected to the A 4500B for remote triggering of the Alert, Evacuation and Bell tones and for remotely cancelling any tones which may be active.

3.1 A 2078B and A 2081 Remote Plates

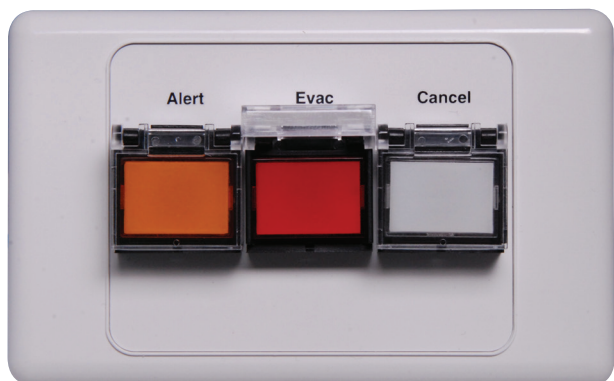

A 2078B



A 2081

The A 2078B wall plate provides a remote means of triggering the Alert and Evacuation tones and the cancel function. While the A 2081 wall plate provides a remote means of triggering the Alert, Evacuation and Bell tones and the cancel function. Connection from the A 2078B is made to the A 4500B via a minimum of 6 wires as shown in Fig 3.1A. Connection is made from the A 2081 to the A 4500B via a minimum of 8 wires as shown in Fig 3.1B.

If standard Cat5 cable is used for the wiring, the plate can be located up to 30m away from the main unit. This can be increased to 100m away using heavier guage cable, which reduces the voltage drop across this distance and ensures the switch leds illuminate.

The Alert/Evac/Chime/Cancel switches on the wall plate are connected to the corresponding contacts on the rear of the A 4500B. While the Alert, Evac and Bell LEDs on the wall plate are connected to the Alert, Evac and Bell 24V outputs of the A 4500B. The cancel LED is not connected. A minimum of six wires can be used on the A 2078B if the ground connections of the Alert and Evac 24V outputs and the Alert/Evac and cancel switch grounds are linked together (see Fig 3.1B).

A minimum of eight wires can be used on the A 2081 if the ground connections of the Alert, Evac and Bell 24V outputs and the Alert/Evac/Chime and cancel switch grounds are linked together (see Fig 3.1B).

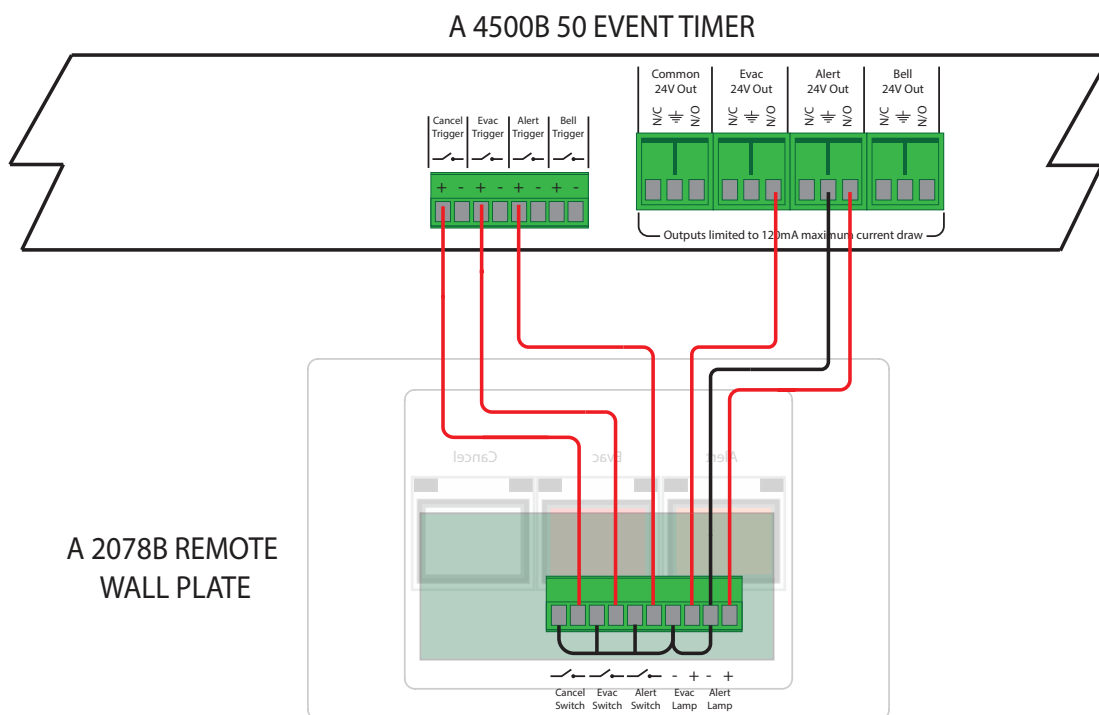

Fig 3.1A

A 4500B 50 EVENT TIMER

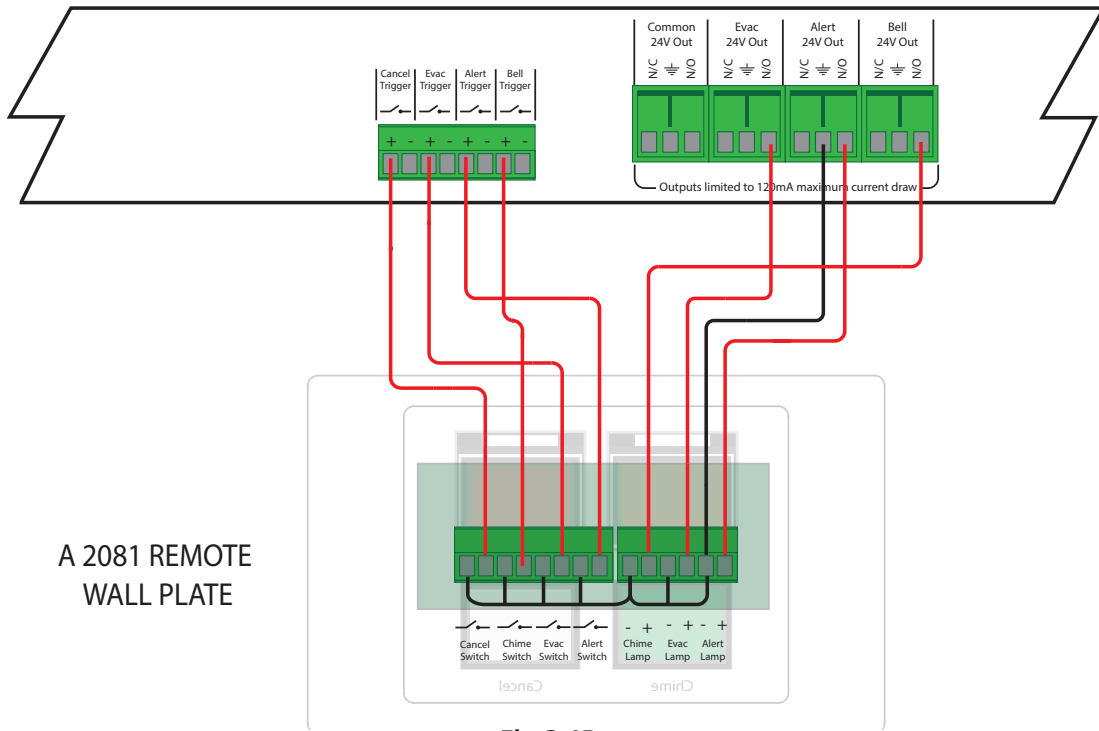

Fig 3.1B

3.2 A 4578, A 4581 and A 4581V Remote Plates

The A 4578, A 4581 and A 4581V wall plates provide a remote means of triggering the Alert, Evacuation and Bell (A 4581 and A 4581V only) tones and the cancel function. The switches are momentary operation and must be pressed for up to 3 seconds to activate, and have protective “flip up” covers to prevent accidental operation.

Connection is made to the A 4500B via standard Cat5e cabling as shown in Fig 3.2 There are two RJ45 ports on the rear of the wall plates, either of which can be used. Only one A 4578, A 4581 or A 4581V wall plate is allowed to be connected to the A 4500B via the “To Wall Plate” RJ45 port.

If the A 4578, A 4581 or A 4581V has a connection problem with the A 4500B main unit, the LED on the wall plate will flash.



A 4581V

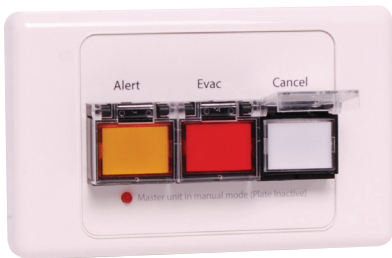

A 4578



A 4581

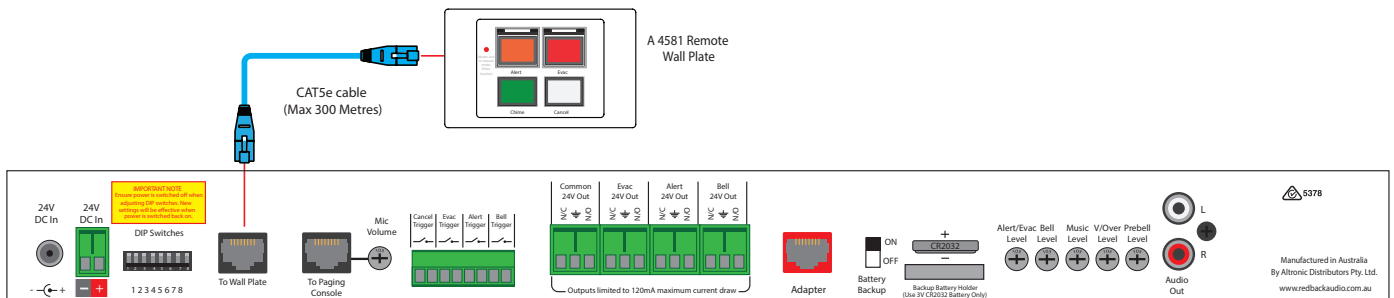

Fig 3.2

4.0 PAGING CONSOLE

4.1 A 4564 OVERVIEW

The A 4564 paging console provides emergency paging and remote selection of "Alert", "Evac", "Chime" and "Cancel" modes on the A 4500B.

Note: This unit is NOT recommended for general paging.

Paging is achieved by simply pressing the PTT (push to talk) switch and then speaking. Paging will override all other functions of the A 4500B including the Alert and Evacuation modes. If the Alert or Evac modes are initiated while paging is occurring, they will be queued and played once paging has finished.

Note: The "Lock On" function is not available with this unit.

Caution: If paging is active while an event time is programmed to occur, the event will not activate. If paging ceases and the finish time for that event hasn't passed, then the event will activate and run for the remaining programmed time.

Provision has been made for the connection of one only paging console which is wired back to the A 4500B via CAT5E cabling to the RJ45 "To Paging Console" port on the rear of the A 4500B (see figure 4.1 for details).

A pre-announcement chime is available at the paging console and through the PA system. Both of these are set by DIP switches on the rear of the paging console.



4.2 A 4564 DIP SWITCH SETTINGS

DIP switch 1 enables the PA system chime on or off.

DIP switch 2 sets the internal chime on or off (*Note: DIP 1 must be ON for the internal chime to function*).

DIP switches 3-4 are not used.

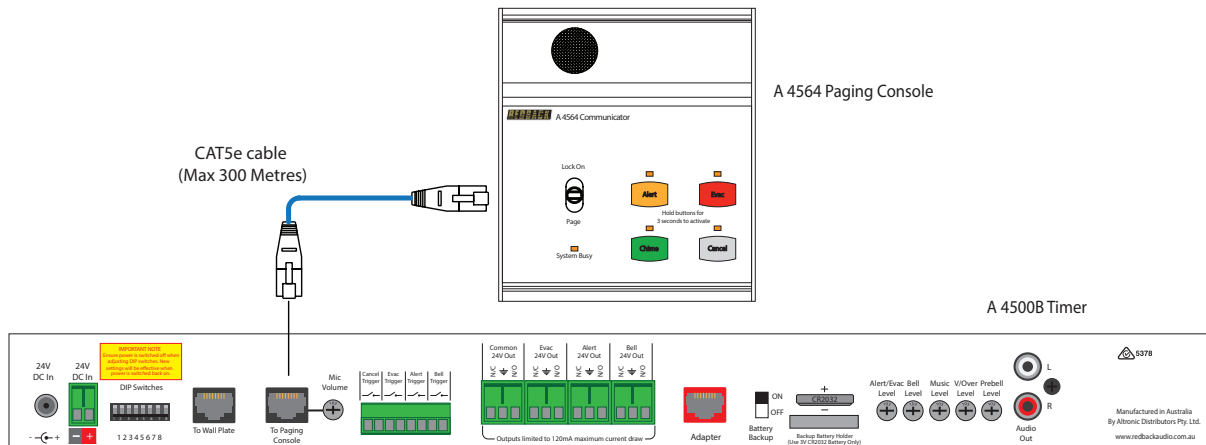
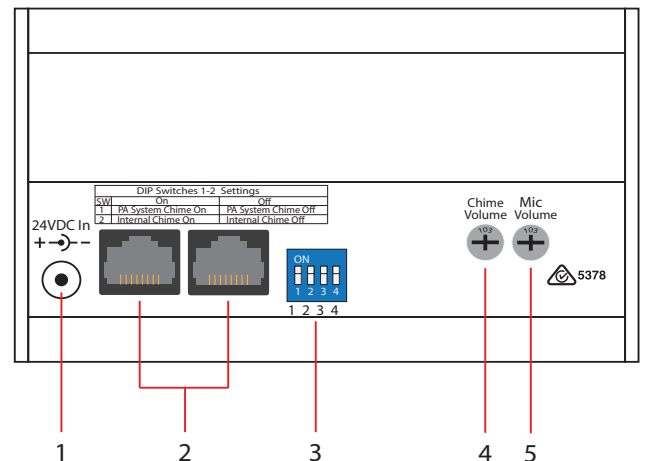

Fig 4.1

4.3 A 4564 REAR PANEL CONNECTIONS

- 1 **24V DC connector**
2.1mm DC jack (centre pin positive).
- 2 **RJ45 connector**
For connection back to the A 4565. Either port can be used.
- 3 **DIP switch options**
These switches set the chime options.
- 4 **Chime volume**
Use this volume to adjust the chime level.
- 5 **Microphone volume**
Use this volume to adjust the microphone level.



IMPORTANT NOTE:
Ensure power is switched off when adjusting DIP switches.
New settings will be effective when power is switched back on.

5.0 TROUBLE SHOOTING

5.1 SYMPTOMS AND REMEDIES

SYMPTOMS	REMEDIES
<i>PC SOFTWARE WILL NOT RUN</i>	The PC software for this product may not run on all PC's. The .NET framework on the PC has to be updated to .NET Framework 4. Available for download on the microsoft website.
<i>ERROR1</i> (Micro SD card not found) <i>ERROR2</i> (Micro SD card not formatted properly) <i>ERROR4</i> (Cannot find an MP3 to play) <i>ERROR7</i> (Cannot Play MP3)	CHECK Micro SD CARD HAS BEEN INSERTED CORRECTLY CHECK Micro SD FORMATTED CORRECTLY CHECK MP3 FILES INSTALLED CHECK FORMAT OF MP3 (It cannot be WAV or AAC) MP3 files cannot be "Read Only" See page 9.
<i>ERROR8</i> (Fault with Configuration File)	CHECK CONFIGURATION FILE (Incorrect time??)
Power switch is illuminated Red but unit doesn't work	The unit is in standby mode. Press the Power/Standby switch. The unit is ON when the Blue ON LED is illuminated.
Unit will not play MP3 files.	Make sure all MP3 files are not "Read Only" . See page 9.
Unit doesn't play an MP3 at the appointed time.	This could be caused by MP3 files which are Read Only. The unit will attempt to play the file but not be able to play it, hence the MP3 will not be played at the appointed time.
Alarm times have been updated by user but the times don't change.	The times are saved to a file named "config.cnf". This file cannot be named anything else. It must also be saved to the root folder of the Micro SD card.

5.2 RJ45 cabling configuration for system components (568A 'Straight through')

System components are connected using "pin to pin" configuration RJ45 data cabling as shown in fig 5.1. When installing ensure all connections are verified with a LAN cable tester before switching any system component on.

Failure to follow the correct wiring configuration may result in damage to system components.

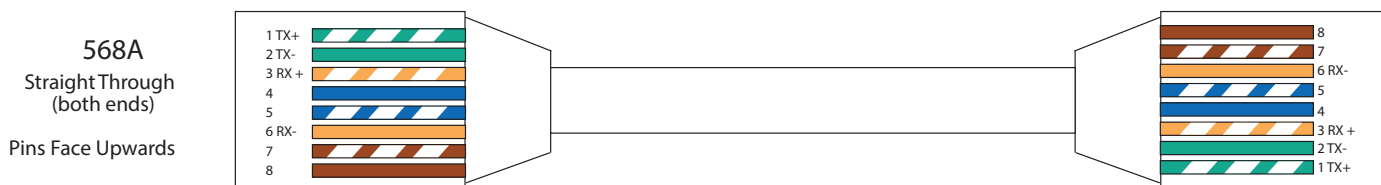

Fig 5.1

WARNING

System components are connected using standard "pin to pin" configuration RJ45 data cabling. When installing ensure all connections are verified before switching any system component on.

Failure to follow the correct wiring configuration may result in damage to system components.

Redback® A 4500B Evacuation Controller & Timer

5.0 FIRMWARE UPDATE

It is possible to update the firmware for this unit by downloading updated versions from www.altronics.com.au or redbackaudio.com.au.

To perform an update, follow these steps.

- 1) Download the Zip file from the website.
- 2) Remove the Micro SD card from the A 4500B and insert it into your PC. (Follow the steps on page 8 to open the Micro SD card).
- 3) Extract the contents of the Zip file to the root folder of the Micro SD Card.
- 4) Rename the extracted .BIN file to update.BIN.
- 5) Remove the Micro SD card from the PC following windows safe card removal procedures.
- 6) With the power turned OFF, insert the Micro SD card back into the A 4500B.
- 7) Turn the A 4500B ON. The unit will check the Micro SD card and if an update is required the A 4500B will perform the update automatically.

6.0 SPECIFICATIONS

OUTPUT LEVEL:.....0dBm
DISTORTION:.....0.01%
FREQ. RESPONSE:.....140Hz - 20kHz
SIGNAL TO NOISE RATIO:
Alert/Evac/Chime:.....-70dB typically

OUTPUT CONNECTORS:

Audio Output:.....RCA Stereo Socket
Common 24V DC Out:.....Screw Terminals
Alert 24V DC Out :..... Screw Terminals
Evac 24V DC Out:.....Screw Terminals
Bell 24V DC Out:.....Screw Terminals

PLEASE NOTE:

Output loads limited to 0.12Amp each

INPUT CONNECTORS:

24V DC Power:.....Screw Terminals
24V DC Power:.....2.1mm DC Jack
Remote Alert, Evac, Bell, Cancel:
.....Screw Terminals

WALLPLATE/PAGING CONSOLE INPUTS:.. RJ45 8P8C

DATA TRANSMISSION:.....Cat5e cabling max 300m

CONTROLS:

Alert/Evac:.....Rear Volume
Voice over:.....Rear Volume
Bell:.....Rear Volume
Prebell:.....Rear Volume
Music:.....Rear Volume
Power:.....On/Off Switch
Alert Switch:.....Illuminated Push Switch
Evac Switch:.....Illuminated Push Switch
Bell Switch:.....Illuminated Push Switch
Cancel Switch:.....Push Switch

INDICATORS:.....Power on, MP3 error, Prebell,
Music, Other MP3 folders

MP3 FILE FORMAT:Minimum 128kbps,
44.1kHz, 32bit, VBR or CBR, Stereo

BACKUP BATTERY :.....3V CR2032

POWER SUPPLY:.....24V DC

DIMENSIONS:≈.....482W x 175D x 44H

WEIGHT: ≈.....2.1 kg

COLOUR: Black

* Specifications subject to change without notice

All Australian made Redback products are covered by a 10 year warranty.

Should a product become faulty please contact us to obtain a return authorisation number. Please ensure you have all the relevant documentation on hand. We do not accept unauthorised returns. Proof of purchase is required so please retain your invoice.