

**Product Guide****C 2123** 165mm (6.5") 100V 5W Twin Cone Ceiling Speaker**C 2123** Fast-Fix Ceiling Speaker

- ✓ Excellent speech intelligibility
- ✓ High quality speaker driver developed for BGM, paging and emergency warning applications
- ✓ Flip-lock mounting system reduces installation time.
- ✓ Offset transformer for reduced mounting depth.
- ✓ Stylish ABS surround and steel mesh grille.
- ✓ 5 year warranty.

**Application**

C 2123 is a standard 100V line speaker & transformer combination designed for general public address, BGM & paging installations. The offset transformer mounting allows mounting in ceilings with limited recess space.

**About Redback® Speaker Drivers**

Each custom designed speaker and transformer combination has been specifically engineered to ensure a wide frequency range and dispersion angle, plus a high sound pressure level (SPL) ensuring excellent music and speech intelligibility; which is highly desirable for paging applications.

Redback® drivers exhibit optimum frequency response and efficiency for BGM & paging applications. The transformers are wound on professional grade grain oriented steel cores for high efficiency and extended frequency response.

Each transformer is fitted with multiple power tapings which are selected via a tab on the top of the transformer.

**Testing**

Redback® drivers are subject to strenuous factory testing reducing the risk of unit failure or performance reduction over time. Each driver has a power rating well above the max tapping of the transformer, ensuring reliable operation and excellent longevity.

**Installation Guidelines**

Redback® "Fast-Fix" speaker utilise a time saving flip lock mounting method. It results in a finish with no visible screw heads or caps.

The flip lock tabs slide outwards as the speaker is screwed into the hole, securing the speaker to the ceiling material from the top side. Suitable for use with any 8-33mm ceiling tile, including gyprock, mineral fibre or fixed gyprock ceilings. We recommend a speaker hole of 195mm. This is easily cut using the T 2314 holesaw.

The neutral white RAL colour of C 2123 provides an architecturally unobtrusive finish to virtually any installation.

The transformer is fitted with a 2 way wire protect screw terminal block.

## Product Guide

**C 2123** 165mm (6.5") 100V 5W Twin Cone Ceiling Speaker



### Dimensions & Transformer Detail

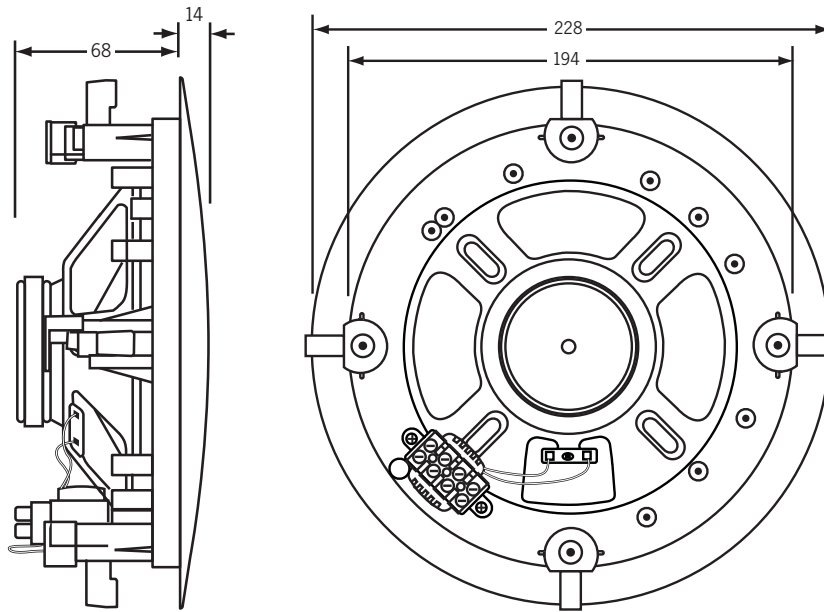

### Specifications

#### Electrical

Power taps:	0.33, 0.66, 1.25, 2.5, 5W
SPL 1W @ 1m:	91dB @ 1kHz (+/- 2dB)
Frequency response:	90Hz - 20kHz
Connection:	2 way terminal block

#### Mechanical

Grille material:	ABS surround, steel mesh grille
Driver construction:	Paper twin cone
Ceiling cutout:	195Ømm
Grille diameter:	228Ømm
Mounting depth:	XXmm (including ceiling tile thickness)
Overall weight:	1kg
Colour:	White

#### Environmental

Operating temperature:	-25°C to +55°C
Relative humidity:	< 95%

#### Additional Installation Accessories

**T 2314** Adjustable 40-270mm holesaw

### Architect Specifications

The speaker shall be a twin cone of 165mm diameter and be fitted with a 100V transformer with power taps of 5W, 2.5W, 1.25W, 0.66W and 0.33W. It shall have a SPL of 91dB and frequency response of 90Hz to 20kHz. The speaker shall be attached to a white steel grill with ABS surround & flip-lock mounting mechanism. The speaker & grill combination shall be a Redback model C 2123.

### Frequency Response (SPL 1W @ 1m)

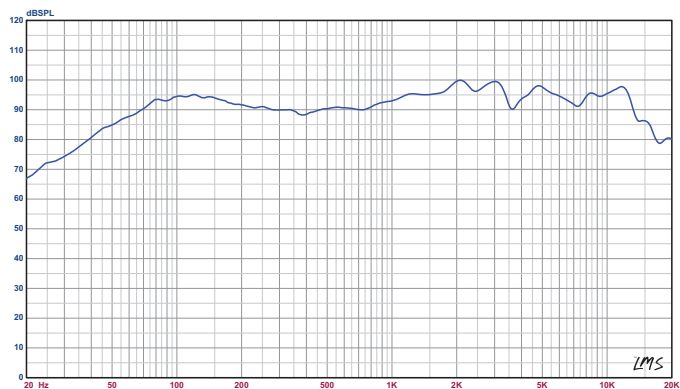

### Polar Plot (Ratio vs Angle)

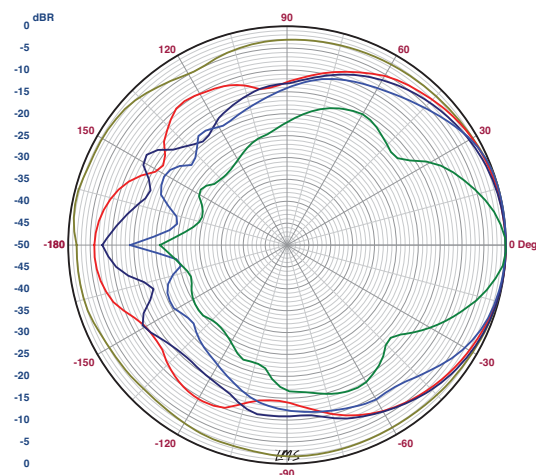

	500Hz	1kHz	2kHz	4kHz	6kHz
BW	360	116	113	84	33
Q-Factor	1.0	3.1	3.2	4.3	11.0
DI	0.0	4.9	5.0	6.3	10.4