

# ES110 Series Electric Strike



The Lockwood Padde Series ES110 is a cost efficient robust electric strike with a solid construction of one-piece cast aluminium body and stainless steel striker. Having a deeper than normal strike-keeper area, ES110 is designed to work with an extensive range of locks and offers the same level of security and reliability usually provided by more expensive electric locking solutions.

Extension lips are available to accommodate the installation of electric strikes on door frames with different thickness. The ES110 product range of patented electric strikes are suitable for use with all access control installations where flexibility, security and lower cost are required.

## Key Features

- All models IP56 Weather resistant
- Fail safe/fail secure changeable on site
- Stainless steel striker for extra strength and durability
- Stainless steel locking pins
- Multi Voltage 12/24Vdc Multi Voltage
- Optional mounting kit
- Installation template
- Suitable For 18mm latch with a 3mm door gap
- 5 Year Tricare Warranty (Padde Series)





## Applications

- Exposed areas
- High traffic areas
- Open in/open out doors
- Suitable for use with all access control systems

## Product Details

<b>Voltage</b>	12/24Vdc
<b>Current</b>	243 mA @ 12Vdc - 187mA @ 24Vdc
<b>Solenoid</b>	Solenoids are rated for continuous use
<b>Monitoring</b>	None
<b>Holding Force</b>	680 kg Static Strength Rating
<b>Endurance</b>	Cycle tested to 1,000,000 operations
<b>Environment</b>	Operational temperature range - 20°C to + 60°C Weather resistant construction Standard. (IP56)
<b>Body</b>	Cast Aluminium Construction
<b>Keeper</b>	Stainless Steel
<b>Latch</b>	Suitable for 15mm latchbolt with 3mm door gap

## Standards and Compliance

	Successfully fire rated up to 4hrs on fire door assemblies in accordance with AS1905.1.2005 (Part 1: Fire resistant door sets)
	Approved to UL1034 (highest level)
	CE Approved
	C-Tick Certified
	Weather Resistant (IP56)

# ES110 Series Electric Strike

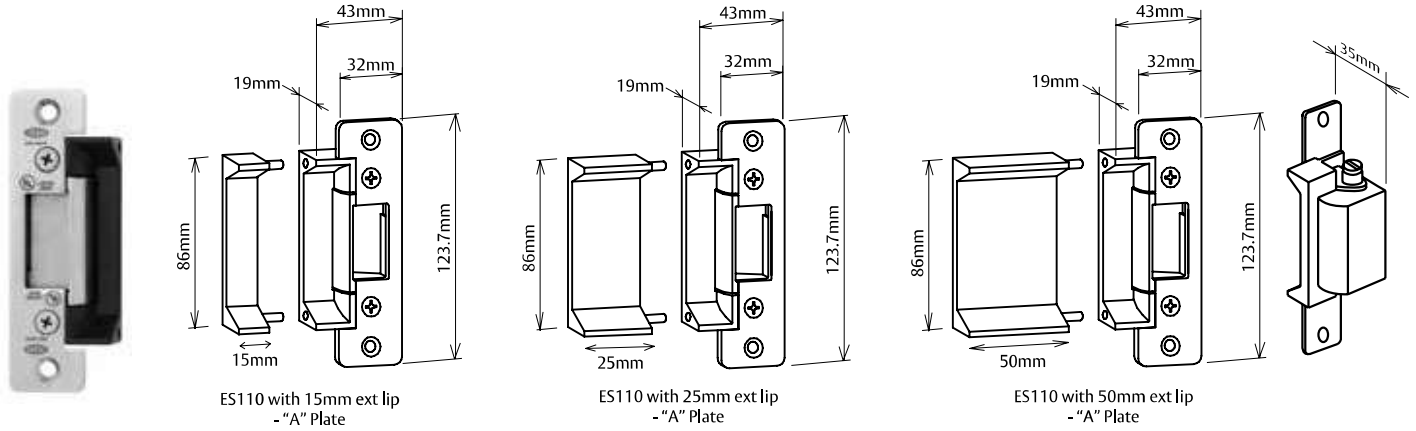

## Ordering Information

Part Number	Product Description
ES110-1M	ES110 12/24Vdc Fail Safe Non-Monitored
ES110-2M	ES110 12/24Vdc Fail Secure Non-Monitored

**Note:** All strikes come pre drilled with Extension lip holes.

## Accessories Ordering Information

Part Number	Product Description
220110-502	15mm Extension Lip (26mm total)
220110-503	25mm Extension Lip (36mm total)
220110-504	50mm Extension Lip (61mm total)
220200-518	Mounting Kit

**Note:** For additional face plate options see over page.

## Specification Statement

Where Power to Lock and Power to Open functions may be required in the same building, the strike must be interchangeable from either "Power to Lock" or "Power to Open" on site.

The electric strike should not consume current greater than 250mA @ 12Vdc - 125mA @ 24Vdc and have a solenoid suitable for continuous use. Certifications must include CE, C-tick and 4hr fire rating.

The strike should have a minimum holding force of 680kg, and an endurance rating of 1 million cycles.

# ES110 Series Electric Strike

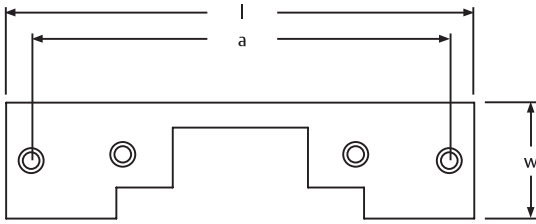

## Faceplates

Faceplate Style	l	w	a	Part Number
A (ANSI Short)	123.7	31.7	104.8	210100-544
B (ANSI Long)	201.6	36.3	185.7	210100-530

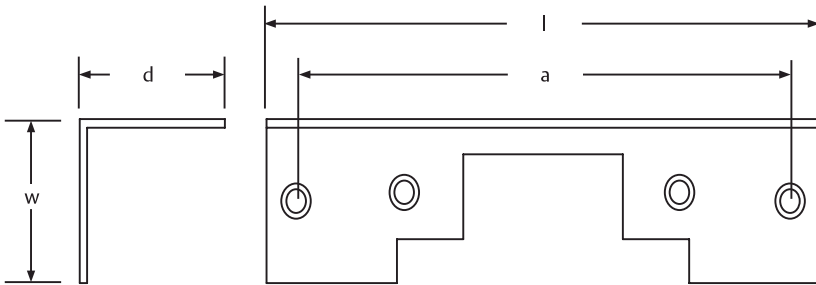

## Faceplates

Faceplate Style	l	w	d	a	Part Number
J	201.6	32	16	185.7	210100-523

## Faceplates

Faceplate Style	l	w	a	b	Part Number
F (UK Sash RH) [DIN Right]	251	25	74	12	210100-528
G (UK Sash LH) [DIN Right]	251	25	74	47	210100-527

**Note:** All face plates are sold separately

