

ES2000 Series Monitored Electric Strike

General Description

The ES2000 series electric strikes are fully monitored high security products manufactured from stainless steel and designed for use with all access control systems. The strikes are suitable for use with hinged doors which require either fire or security control as part of a building management system.

These strikes are flexible and can be changed from fail safe to fail secure, mounted on the left or right hand side of the door and are available in 12 or 24Vdc.

They offer a strong, dependable and long-lasting electric strike solution with a 850kg holding force and endurance rating of 1 million cycles.

Key Features

- Fully monitored – strike locked and door latched
- Fail safe/fail secure changeable on site
- High security
- 4 Hour fire rating
- 850kg holding force
- 1 million cycles endurance rating
- Cast stainless steel body
- Stainless steel locking pins
- SCEC Endorsed
- Low Current consumption - Max 175ma @12Vdc
- Solenoid rated for continuous use
- Mounting kit supplied as standard
- **TRICARE**® 5 Year Warranty

Applications

- High traffic areas
- Fire rated door sets
- Open in/open out doors
- Suitable for use with all access control systems





Standards and Compliance

S3 (Security) Australian Lock Standard (AS4145.2.1993)

D3 (Durability) Australian Lock Standard (AS4145.2.1993)

BSI BS 5872 Approved

 Successfully fire rated up to 4hrs on fire door assemblies in accordance with AS1905.1. 2005 (Part 1: Fire resistant door sets)

 Approved to UL1034 (highest level)

 CE Approved

 C-Tick Certified

SCEC endorsed for secure areas

ES2000 Series Monitored Electric Strike

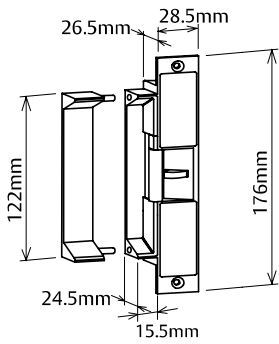

ES2000 with 25mm Extension Lip

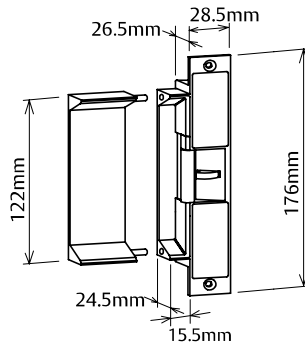

ES2000 with 50mm Extension Lip

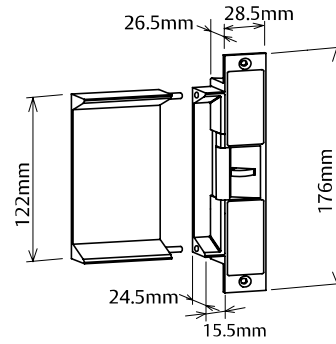

ES2000 with 75mm Extension Lip

ES2000 Technical Information

Voltage	12 or 24Vdc
Current	175 mA @ 12Vdc - 88 mA @ 24Vdc
Solenoids	Solenoids are rated for continuous use
Monitoring	Solenoid Monitor - 1 amp NO/NC microswitch Door/Latch Monitor - 1 amp NO/NC microswitch
Holding Force	850kg Static Strength Rating
Endurance	Cycle tested to 1,000,000 operations
Latch	Suitable for 15mm latch bolt with 3 mm door gap
Environment	Operational temperature range - 20°C to +60°C
Body	Solid Stainless Steel Construction
Keeper	Stainless Steel

Specification Statement

The strike should be constructed of stainless steel, have a minimum holding force of 850kg and have an endurance rating of 1 million cycles. Monitoring must include independent door / latch & solenoid monitoring. The one strike must be changeable from fail safe to fail secure on site where required. The strike should not consume current greater than 175mA at 12Vdc and have a solenoid rated for continuous use. Certifications must include CE, C-Tick and 4 hr fire rating.

Ordering Information

Product Description	Part Number
12V Fail Safe Electric Strike	102001-000
12V Fail Safe Electric Strike with no Extension Lip	102001-010
12V Fail Safe with 8mm Extension Lip	102001-020
12V Fail Safe with Extension Lip Holes	102001-060
12V Fail Secure Electric Strike	102002-000
12V Fail Safe Electric Strike - Replacement for Padde MKV1	102001-900
24V Fail Safe Electric Strike	102003-000
24V Fail Safe with Extension Lip Holes	102003-060
24V Fail Safe - Replacement for Padde MKV1	102003-900
24V Fail Secure Electric Strike	102004-000

Accessories

Product Description	Part Number
13mm Rebate Plate	210100-541
25mm Extension Lip (40.5mm total)	220200-505
50mm Extension Lip (65.5mm total)	220200-506
75mm Extension Lip (90.5mm total)	220200-507
Dummy Fixed Striker	100200-000
Mounting Kit	220200-519