

# Z4 and Z8 Double Series Non Monitored



The Lockwood Padde Series Double Series Electromagnetic Locks operate with holding forces from 500kg up to 1160kg. Covering a range of applications these magnets are ideal for applications from access ways through to high use commercial swing doors. With fixing options including wood, aluminium and steel constructions as well as glass door applications, the range caters to most electromagnetic needs.

## Key Features

- Fail-Safe: unlocks when power is removed
- Easy installation: suitable for both new and retrofit usage
- High holding force: refer to the technical data overleaf
- Self-alignment: armature plate pivots to accommodate door drop
- Silent operation: no humming or buzzing
- Dual voltage: site selectable 12 or 24 Vdc
- Instantaneous release: smart electronics on the electromagnets eliminate residual magnetism
- 5 Year Tricare Warranty (Padde Series)



## Applications

- Aluminium doors
- Double swing doors
- Access control
- Surface mount for inswing and outswing doors

## Product Details

	Z4 Magnet	Z8 Magnet
<b>Holding Force</b>	500kg-560kg	1100kg-1160kg
<b>Dimensions</b>	(L)476 x (H)48 x (D) 27 mm	(L)532 x (H)72 x (D) 40 mm
<b>Voltage</b>	12Vdc/ 24Vdc ±10%	12Vdc/ 24Vdc ±10%
<b>Current</b>	900mA @ (12Vdc) 450mA @ (24Vdc)	1024mA @ (12Vdc) 512mA @ (24Vdc)
<b>Monitoring</b>	None	None
<b>Operating Temperature</b>	-25 to 55 Degrees	-25 to 55 Degrees
<b>Operating Humidity</b>	0-95%	0-95%

## Standards and Compliance

	Successfully fire rated up to 4 hours on fire door assemblies in accordance with AS1905.1.2005 (Part 1: Fire Resistant Doorsets)
	CE Approved
	RCM Certified

# Z4 and Z8 Double Series Non Monitored



Z4 Double Electromagnetic Lock - Non Monitored



Z8 Double Electromagnetic Lock - Non Monitored

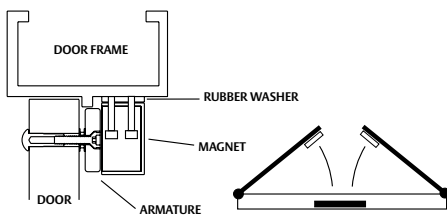

Out swinging door using the standard mounting plate.

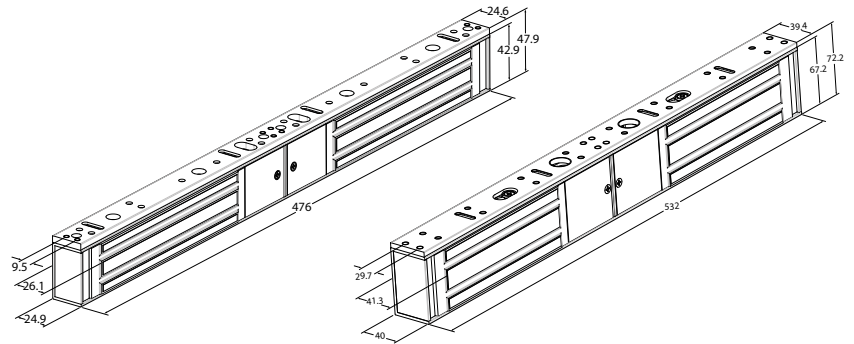

Z4 Electromagnetic Lock

Z8 Electromagnetic Lock

## Ordering Information

Part Number	Product Description
EMZ4-DN	EMZ4 E/Magnet 12/24Vdc Double Non Monitored
EMZ8-DN	EMZ8 E/Magnet 12/24Vdc Double Non Monitored
<b>Accessories</b>	
EMZ4B-DLZ	EMZ4 Bracket Double L & Z
EMZ4B-AN	EMZ4 Bracket Armature Non Monitored
EMZ4B-DMP	EMZ4 Bracket Double Mounting Plate
EMZ4SP-SC	EMZ4 Spare Part Screw Kit
EMZ8B-DLZ	EMZ8 Bracket Double L & Z
EMZ8B-AN	EMZ8 Bracket Armature Non Monitored
EMZ8B-DMP	EMZ8 Bracket Double Mounting Plate
EMZ8SP-SC	EMZ8 Spare Part Screw Kit

## Specification Statement

The Double Series Electromagnetic Lock should be constructed in an aluminium case with heavy duty electromagnet. The range only operates in Fail Safe mode and relies on a secondary lock or battery backup system. The lock needs to be equipped with “smart electronics” that have zero residual magnetism (instantaneous release). This is crucial for correct operation.