

Electric Strikes



We take the worry out of
protecting what's valuable to you.
Lockwood: *no worries*[®]

LOCKWOOD

ASSA ABLOY

5YEAR

**TRICARE
WARRANTY**

PADDE SERIES

www.lockweb.com.au

Contents



EL110 Electric Cabinet Lock

Electric Strikes Range
page 3



ES110 Series Electric Strike

Electric Strikes Range
page 5



ES150 Series Surface Mounted Electric Strike

Electric Strikes Range
page 8



ES200 Series Non Monitored Electric Strike

Electric Strikes Range
page 10



ES2000 Series Monitored Electric Strike

Electric Strikes Range
page 12



ES2100 Series Door Monitored Electric Strike

Electric Strikes Range
page 14



ES2600 Series Panic Bar Electric Strike

Electric Strikes Range
page 17



ES3200 Series Monitored Electric Strike

Electric Strikes Range
page 19



ES9000 Series Pre-Load Strike

Electric Strikes Range
page 21

EL110 Electric Cabinet Lock

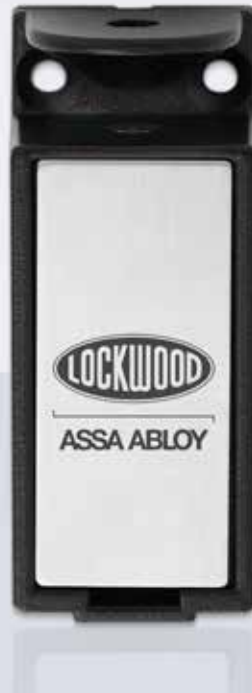

The Lockwood Padde Series EL110 electric cabinet lock is a compact, cast aluminium lock specially designed for cabinets having either swing or sliding doors. The cabinet lock can be surface mounted either vertically or horizontally and offers maximum flexibility for ease of installation.

EL110 can also be controlled by any existing access control system or simply controlled through a remote keypad or keyswitch. The EL110 is cost efficient, robust, easy to install and suitable for one or multiple cabinet applications.

Key Features

- Fail safe/fail secure changeable on site
- Flexible alignment: has a 5mm XY adjustment after installation
- Low current consumption: uses only 187mA @ 12Vdc
- Available in 12Vdc
- Self latching in fail secure mode
- Solenoid rated for continuous use
- 5 Year Tricare Warranty (Padde Series)



Applications

- Cabinet locking
- Swing or sliding cabinet doors

Product Details

Voltage	12Vdc
Current	187mA @ 12Vdc.
Solenoid	Solenoids are rated for continuous use.
Monitoring	None
Strength	Holding force 150kg
Endurance	Cycle tested to 1,000,000 operations
Environment	Operational temperature range -20c to +60c
Body	Cast Aluminium Construction

Standards and Compliance

	CE Approved
	C-Tick Certified

EL110 Electric Cabinet Lock

Front Engagement



Exterior

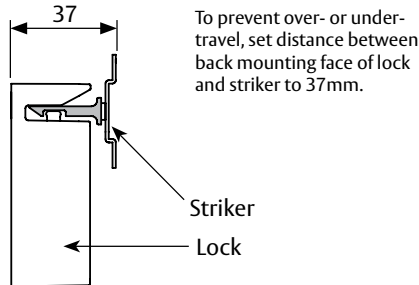

Lock and Strike Dimensions

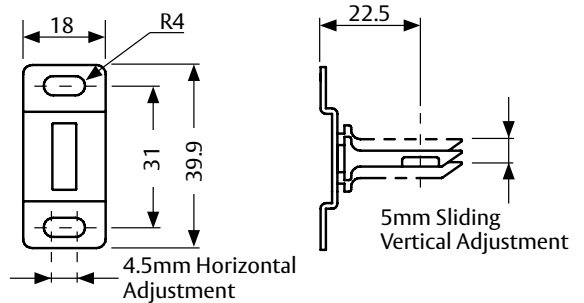

Side Engagement

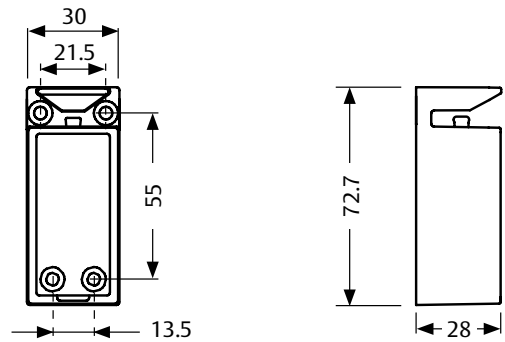
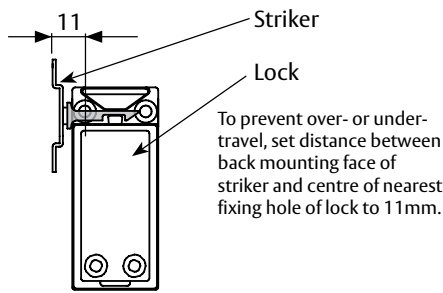

Ordering Information

Part Number	Product Description
EL110-1	EL110 Cabinet Lock 12Vdc Fail Safe Non Monitored
EL110-2	EL110 Cabinet Lock 12Vdc Fail Secure Non Monitored

Specification Statement

The strike which is to be surface mounted and constructed of cast aluminium, should be self latching when used in fail secure mode. The lock must be capable of being changed from fail safe to fail secure on site. Lock alignment must be adjustable up to 5mm in both "x" and "y" directions both during and after installation. The lock should consume not greater than 187mA @12Vdc and have a solenoid rated for continuous use. Electrical certifications must include CE and C-tick.

ES110 Series Electric Strike



The Lockwood Padde Series ES110 is a cost efficient robust electric strike with a solid construction of one-piece cast aluminium body and stainless steel striker. Having a deeper than normal strike-keeper area, ES110 is designed to work with an extensive range of locks and offers the same level of security and reliability usually provided by more expensive electric locking solutions.

Extension lips are available to accommodate the installation of electric strikes on door frames with different thickness. The ES110 product range of patented electric strikes are suitable for use with all access control installations where flexibility, security and lower cost are required.

Key Features

- All models IP56 Weather resistant
- Fail safe/fail secure changeable on site
- Stainless steel striker for extra strength and durability
- Stainless steel locking pins
- Available in 12 or 24Vdc
- Optional mounting kit
- Installation template
- Suitable For 18mm latch with a 3mm door gap
- 5 Year Tricare Warranty (Padde Series)





Applications

- Exposed areas
- High traffic areas
- Open in/open out doors
- Suitable for use with all access control systems

Product Details

Voltage	12 or 24Vdc
Current	243 mA @ 12Vdc - 187mA @ 24Vdc
Solenoid	Solenoids are rated for continuous use
Monitoring	None
Holding Force	680 kg Static Strength Rating
Endurance	Cycle tested to 1,000,000 operations
Environment	Operational temperature range - 20°C to + 60°C Weather resistant construction Standard. (IP56)
Body	Cast Aluminium Construction
Keeper	Stainless Steel
Latch	Suitable for 15mm latchbolt with 3mm door gap

Standards and Compliance

	Successfully fire rated up to 4hrs on fire door assemblies in accordance with AS1905.1.2005 (Part 1: Fire resistant door sets)
	Approved to UL1034 (highest level)
	CE Approved
	C-Tick Certified
	Weather Resistant (IP56)

ES110 Series Electric Strike

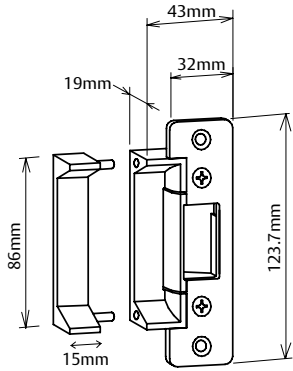

ES110 with 15mm ext lip
- "A" Plate

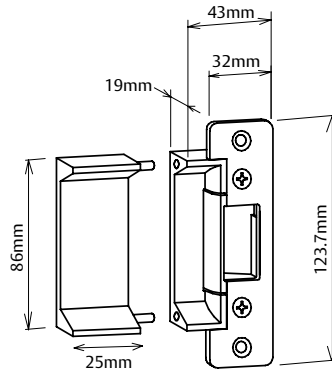

ES110 with 25mm ext lip
- "A" Plate

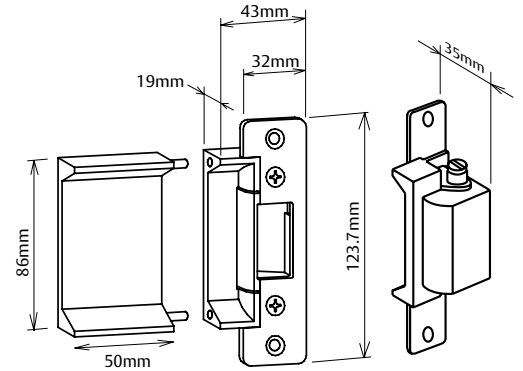

ES110 with 50mm ext lip
- "A" Plate

Ordering Information

Part Number	Product Description
ES110-1	ES110 E/Strike 12Vdc Fail Safe Non Monitored
ES110-2	ES110 E/Strike 12Vdc Fail Secure Non Monitored
ES110-3	ES110 E/Strike 24Vdc Fail Safe Non Monitored
ES110-4	ES110 E/Strike 24Vdc Fail Secure Non Monitored

Note: All strikes come pre drilled with Extension lip holes.

Accessories Ordering Information

Part Number	Product Description
220110-502	15mm Extension Lip (26mm total)
220110-503	25mm Extension Lip (36mm total)
220110-504	50mm Extension Lip (61mm total)
220200-518	Mounting Kit

Note: For additional face plate options see over page.

Specification Statement

Where Power to Lock and Power to Open functions may be required in the same building, the strike must be interchangeable from either "Power to Lock" or "Power to Open" on site.

The electric strike should not consume current greater than 243mA @ 12Vdc or 187mA @ 24Vdc and have a solenoid suitable for continuous use. Certifications must include CE, C-tick and 4hr fire rating.

The strike should have a minimum holding force of 680kg, and an endurance rating of 1 million cycles.

ES110 Series Electric Strike

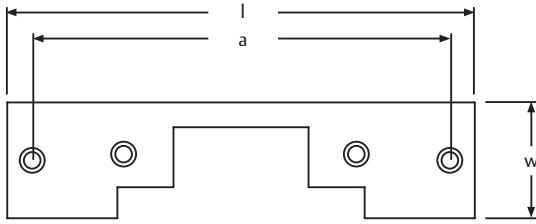

Faceplates

Faceplate Style	l	w	a	Part Number
A (ANSI Short)	123.7	31.7	104.8	210100-544
B (ANSI Long)	201.6	36.3	185.7	210100-530

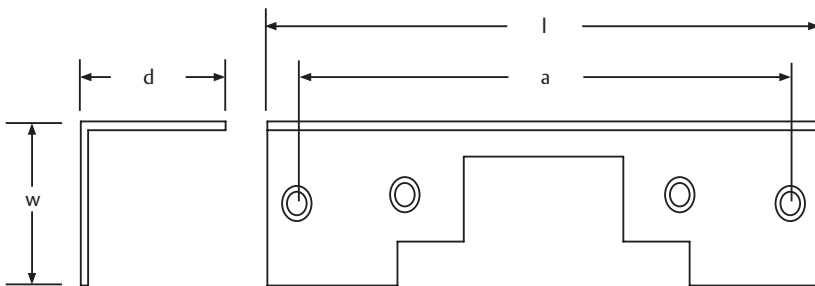

Faceplates

Faceplate Style	l	w	d	a	Part Number
J	201.6	32	16	185.7	210100-523

Faceplates

Faceplate Style	l	w	a	b	Part Number
F (UK Sash RH) [DIN Right]	251	25	74	12	210100-528
G (UK Sash LH) [DIN Right]	251	25	74	47	210100-527
L (Short Sash RH) [DIN Right]	182	32	36.5	14.7	210100-534

Note: All face plates are sold separately

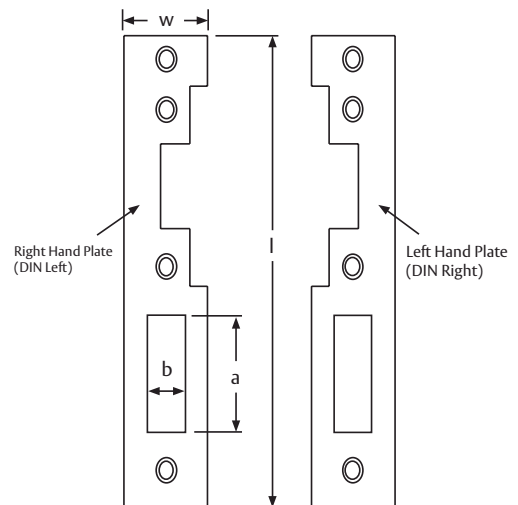

ES150 Series Surface Mounted Electric Strike



The Lockwood Padde Series ES150 is a surface mounted electric strike suitable for use with rim or surface type dead latches. This strike is easy to install and can be simply controlled by a keypad, keyswitch or integrated into any access control system.

ES150 offers high levels of security and features usually provided by more expensive electric locking solutions. The electric strike can be easily installed on steel and wooden door frames. A weather resistant version is also available for exterior applications.

Key Features

- Configure to fail safe or fail secure
- Easy installation suitable for steel and wooden door frames
- Stainless steel striker for extra strength and durability
- Available in 12 or 24Vdc
- Solenoid rated for continuous use
- IP56 weather resistant version available
- 5 Year Tricare Warranty (Padde Series)

Applications

- Surface or rim mounted applications
- Suitable for use with all access control systems
- Exposed areas

Product Details

Voltage	12 or 24Vdc
Current	243 mA @ 12Vdc - 187mA @ 24Vdc
Solenoid	Solenoids rated for continuous use
Monitoring	None
Holding Force	680 kg Static Strength Rating
Endurance	Cycle tested to 1,000,000 operations
Environment	Operational temperature range - 20°C to + 60°C Weather resistant construction Standard. (IP56)
Body	Solid Stainless Steel Construction
Keeper	Stainless Steel
Latch	Suitable for 15mm latchbolt with 3mm door gap

Standards and Compliance

	CE Approved
	C-Tick Certified
	IP56 Rated

ES150 Series Surface Mounted Electric Strike

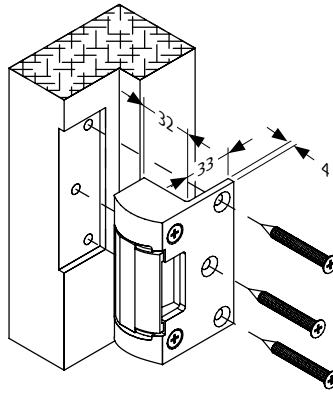
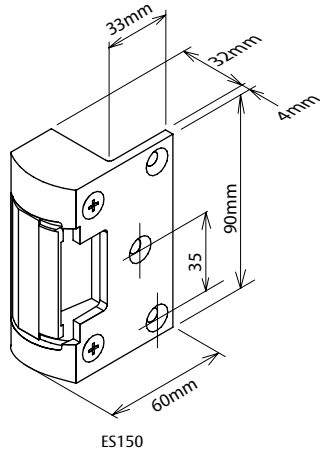

Ensure 1mm Working Gap without Mechanical Interference

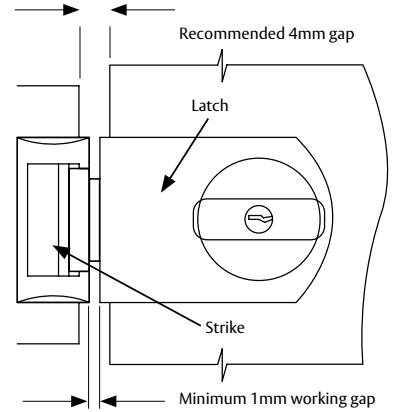

Ordering Information

Part Number	Product Description
ES150-1	ES150 E/Strike 12Vdc Fail Safe Non Monitored
ES150-3	ES150 E/Strike 24Vdc Fail Safe Non Monitored

Note: Change from Fail Safe (PTL) to Fail Secure (PTO) as required

Specification Statement

The electric strike must be suitable for surface mount applications for use with rim or surface mount door locks.

Where Power To Lock and Power To Open functions may be required in the same building, an individual strike is interchangeable from either "Power to Lock" or "Power to Open" on site.

The electric strike should not consume current greater than 243mA @ 12Vdc or 187mA @ 24Vdc. Certifications must include CE and C-Tick.

The strike should be tested to 1 million operations and have a minimum holding force not less than 680kg.

ES200 Non Monitored Series Electric Strike



The Lockwood Padde Series ES200 series electric strikes are high security products manufactured from stainless steel and designed for use with all access control systems. The strikes are suitable for use with hinged doors which require either fire or security control as part of a building management system.

These strikes are flexible and can be changed from fail safe to fail secure, mounted on the left or right hand side of the door and are available in 12 or 24Vdc.

They offer a strong, dependable and long-lasting electric strike solution.

Key Features

- Fail safe/fail secure changeable on site
- High security
- 4 Hour fire rating
- 850kg holding force
- 1 million cycles endurance rating
- Cast stainless steel body
- Stainless steel locking pins
- Low Current consumption - Max 175mA @12Vdc
- Mounting kit supplied as standard
- 5 Year Tricare Warranty (Padde Series)





Applications

- High traffic areas
- Fire rated door sets
- Open in/open out doors
- Suitable for use with all access control systems

Product Details

Voltage	12 or 24Vdc
Current	175 mA @ 12Vdc - 88mA @ 24Vdc
Solenoids	Solenoids are rated for continuous use
Monitoring	None
Holding Force	850kg Static Strength Rating
Endurance	Cycle tested to 1,000,000 operations
Latch	Suitable for 15mm latch bolt with 3mm door gap
Environment	Operational temperature range -20°C to +60°C
Body	Solid Stainless Steel Construction
Keeper	Stainless Steel

Standards and Compliance

S3	High security for maximum protection (AS4145.2:1993).
D3	High durability for maximum frequency usage.
	Successfully fire rated up to 4hrs on fire door assemblies in accordance with AS1905.1. 2005 (Part 1: Fire resistant door sets)
	Approved to UL1034 (highest level)
	CE Approved
	C-Tick Certified

ES200 Series Electric Strike

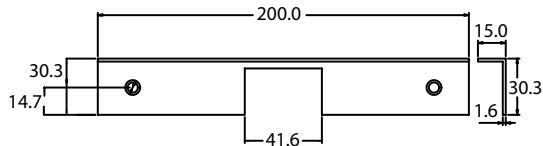

13mm Rebate Kit

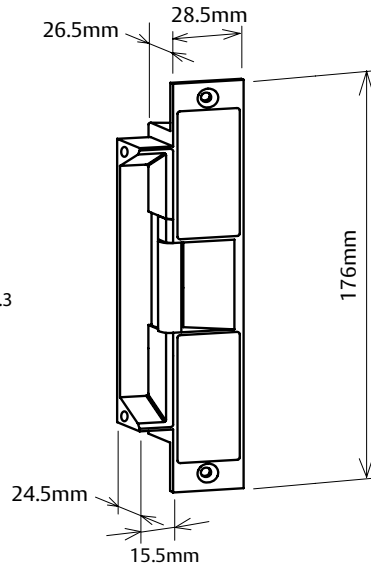

ES200 Electric Strike

Ordering Information

Part Number	Product Description
ES200-1	ES200 E/Strike 12Vdc Fail Safe Non Monitored
ES200-2	ES200 E/Strike 12Vdc Fail Secure Non Monitored
ES200-3	ES200 E/Strike 24Vdc Fail Safe Non Monitored

Note: Change from Fail Safe (PTL) to Fail Secure (PTO) as required

Accessories Ordering Information

Part Number	Product Description
210100-541	13mm Rebate Plate
220200-519	Mounting Kit

Note: If Extension Lips are required, use ES2100 Electric Strike (Page 13)

Specification Statement

The strike should be constructed of stainless steel, have a minimum holding force of 850kg and have an endurance rating of 1 million cycles. The one strike must be changeable from fail safe to fail secure on site where required. The strike should not consume current greater than 175mA at 12Vdc and have a solenoid rated for continuous use. Certifications must include CE, C-Tick and 4 hr fire rating.

ES2000 Series Monitored Electric Strike



The Lockwood Padde Series ES2000 series electric strikes are fully monitored high security products manufactured from stainless steel and designed for use with all access control systems. The strikes are suitable for use with hinged doors which require either fire or security control as part of a building management system.

These strikes are flexible and can be changed from fail safe to fail secure, mounted on the left or right hand side of the door and are available in 12Vdc.

They offer a strong, dependable and long-lasting electric strike solution with a 850kg holding force and endurance rating of 1 million cycles.

Key Features

- Fully monitored – strike locked and door latched
- Fail safe/fail secure changeable on site
- High security
- 4 Hour fire rating
- 850kg holding force
- 1 million cycles endurance rating
- Cast stainless steel body
- Stainless steel locking pins
- SCEC Endorsed
- Low Current consumption - Max 175ma @12Vdc
- Solenoid rated for continuous use
- Mounting kit supplied as standard
- 5 Year Tricare Warranty (Padde Series)



Applications

- High traffic areas
- Fire rated door sets
- Open in/open out doors
- Suitable for use with all access control systems

Product Details

Voltage	12Vdc
Current	175 mA @ 12Vdc
Solenoids	Solenoids are rated for continuous use
Monitoring	Solenoid Monitor - 1 amp NO/NC microswitch Door/Latch Monitor - 1 amp NO/NC microswitch
Holding Force	850kg Static Strength Rating
Endurance	Cycle tested to 1,000,000 operations
Latch	Suitable for 15mm latch bolt with 3mm door gap
Environment	Operational temperature range -20°C to +60°C
Body	Solid Stainless Steel Construction
Keeper	Stainless Steel

Standards and Compliance

S3	(Security) Australian Lock Standard (AS4145.2:1993).
D3	(Durability) Australian Lock Standard (AS4145.2:1993)
	Successfully fire rated up to 4hrs on fire door assemblies in accordance with AS1905.1. 2005 (Part 1: Fire resistant door sets)
	Approved to UL1034 (highest level)
	CE Approved
	C-Tick Certified
	SCEC endorsed for secure areas

ES2000 Series Monitored Electric Strike

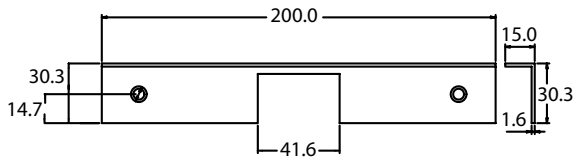

13mm Rebate Kit

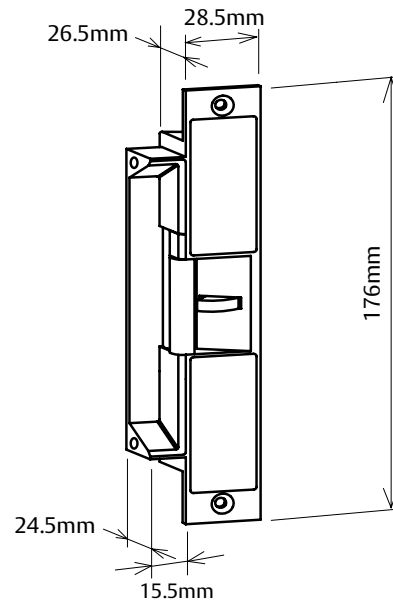

ES2000 Electric Strike

Ordering Information

Part Number	Product Description
ES2000-1	ES2000 E/Strike 12Vdc Fail Safe Monitored
ES2000-2	ES2000 E/Strike 12Vdc Fail Secure Monitored

Note: If 24vdc version is required use ES2100 Electric Strike

Accessories Ordering Information

Part Number	Product Description
210100-541	13mm Rebate Plate
220200-519	Mounting Kit

Note: If Extension Lips are required, use ES2100 Electric Strike (Page 13)

Specification Statement

The strike should be constructed of stainless steel, have a minimum holding force of 850kg and have an endurance rating of 1 million cycles. Monitoring must include independent door / latch & solenoid monitoring. The one strike must be changeable from fail safe to fail secure on site where required. The strike should not consume current greater than 175mA at 12Vdc and have a solenoid rated for continuous use. Certifications must include CE, C-Tick and 4 hr fire rating.

ES2100 Series Monitored Electric Strike



The Lockwood Padde Series ES2100 is the latest product to join the iconic Lockwood range of electric strikes. Tested in accordance with Australian standards this strike offers superior strength, and is durability tested to 1.5 million operations.

Standard features include variable voltage, patented field selectable fail safe/fail secure mode change and a unique integrated door position switch.

Integrated Door Position Switch

The ES2100 now offers a unique new monitoring feature not available in other strikes on the market today. The strike has an integrated reed switch that when combined with a specialised Lockwood mortice lock, provides door position monitoring. The strike is supplied with a standard door magnet for use with cylindrical latches. Lockwood mortice locks and face plate accessories are sold separately.

Key Features

- Patented field selectable fail safe/fail secure
- Multi voltage 10–30Vdc
- Fully monitored:
 - Integrated door position (reed) switch
 - Solenoid/Locked
 - Latch position
- 1000kg holding force
- 4hr fire rating
- Mounting tabs as supplied standard
- 5 Year Tricare Warranty (Padde Series)
- Weather Resistant (IP54)
- Built in Protection Diode



Applications

- High traffic areas
- Fire rated door sets
- Open in/open out doors
- Suitable for use with all access control systems
- Doors requiring additional door position monitoring

Product Details

Voltage	Variable 10–30Vdc
Current	200mA @ 12Vdc - 120mA @ 24Vdc
Solenoids	Rated for continuous use
Monitoring	Latch Strike locked Door position (reed switch)
Holding Force	1000kg static strength rating
Endurance	Cycle tested to 1.5 million operations
Latch	Suitable for 15mm latch bolt with 3mm door gap
Environment	Operational temperature range -20°C to +60°C
Body and Keeper	Stainless Steel

Standards and Compliance

SL8	(Security) Australian Lock Standard (AS4145.2.2008).
D8	(Durability) Australian Lock Standard (AS4145.2.2008)
	Successfully fire rated up to 4hrs on fire door assemblies in accordance with AS1905.1.2005
	CE Approved
	C-Tick Certified

SCEC Approved for Security Level 3

ES2100 Series Monitored Electric Strike



Integrated magnets
Align with integrated reed switch.

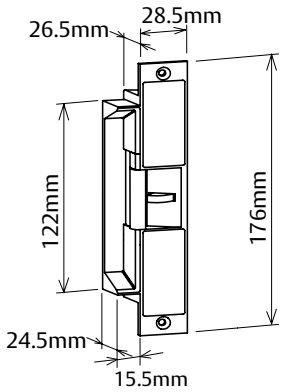

ES2100 Electric Strike

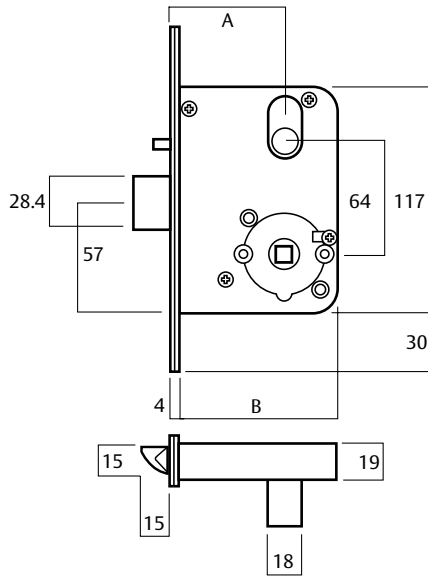

3570 Series Mortice Lock

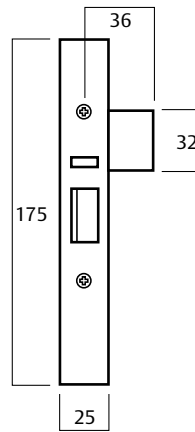

Magnet Faceplate



	STD Backset	Extended Backset
Dimension A	60	127
Dimension B	84	151



PADDE SERIES

ES2100 Series Monitored Electric Strike

Ordering Information

Part Number	Product Description
ES2100	ES2100 E/Strike 12-30Vdc M/Function Door Monitored
ES2100-010	ES2100 E/Strike 12-30Vdc M/Function Door Monitored No Lip
ES2100-020	ES2100 E/Strike 12-30Vdc M/Function Door Monitored 8mm Lip

Ordering Notes:

When using integrated door position switch monitoring:

- Electric strikes are supplied with door magnet for cylindrical locksets only.
- Lockwood Mortice Locks and face plates are sold separately.
- All strikes are factory set to fail safe (PTL) configuration. Configuration to Fail Secure (PTO) is easily set on site.
- All Strikes come pre drilled with Extension lip holes

Specification Statement

The strike should be constructed of stainless steel, have a minimum holding force of 1000kg and an endurance rating of 1.5 million cycles. Monitoring must include independent latch and solenoid monitoring. The strike shall have an integrated reed switch for door position monitoring and used in conjunction with Lockwood 3572MAGSC mortice lock. Certifications must include CE, C-tick and 4 hr fire rating.

Accessories Ordering Information

Part Number	Product Description
3572MAGSC	Lockwood 3572 Series Primary lock with magnet face plate
SP3570-2100SSS	Magnet face plate – suits Lockwood 3570 series mortice lock
220200-519	Mounting Kit
210100-541	13mm Rebate Plate
220200-505	25mm Extension Lip (40.5mm total)
220200-506	50mm Extension Lip (65.5mm total)
220200-507	75mm Extension Lip (90.5mm total)

ES2600 Series Panic Bar Monitored Electric Strike



The Lockwood Padde Series ES2600 Series surface mounted electric strikes are high security products manufactured from stainless steel and designed to be used with existing and new panic bars fitted to emergency doors.

When used in conjunction with a standard access control system, these strikes convert "Exit only" doors with "Pullman type" latches into a full access controlled door, thereby allowing authorised access from the secure side.

The ES2600 series are fully monitored with both solenoid and latch/door monitoring functions & can be changed from fail safe to fail secure

on site.

Key Features

- Fail safe/fail secure changeable on site
- High security
- Available in 12 or 24Vdc
- 650kg holding force
- 1 million cycles endurance rating
- Body depth only 27mm
- Cast stainless steel body
- Low current consumption - max 175Ma @ 12Vdc
- Continuously rated solenoid
- Installation template
- 5 Year Tricare Warranty (Padde Series)



Applications

- For use with panic bars
- Surface mount
- Egress doors
- Fire rated door sets
- Open out door sets
- Suitable for use with all access control systems

Product Details

Voltage	12 or 24Vdc
Current	175mA @ 12Vdc - 88mA @ 24Vdc
Solenoids	Solenoids rated for continuous use.
Monitoring	Solenoid Monitor - 1 amp NO/NC microswitch Door / Latch Monitor - 1 amp NO/NC microswitch
Holding Force	650kg Static Strength Rating
Endurance	Cycle tested to 1,000,000 operations
Additional	Anti friction roller (patented) Suits panic bars with 15 to 20mm Pullman latch projection
Environment	Operational temperature range -20°C to +60°C
Body	Solid Stainless Steel Construction
Keeper	Stainless Steel
Latch	Suitable for 15-20mm pullman latch

Standards and Compliance

	Approved to UL1034 (highest level)
	CE Approved
	C-Tick Certified

ES2600 Monitored Electric Strike

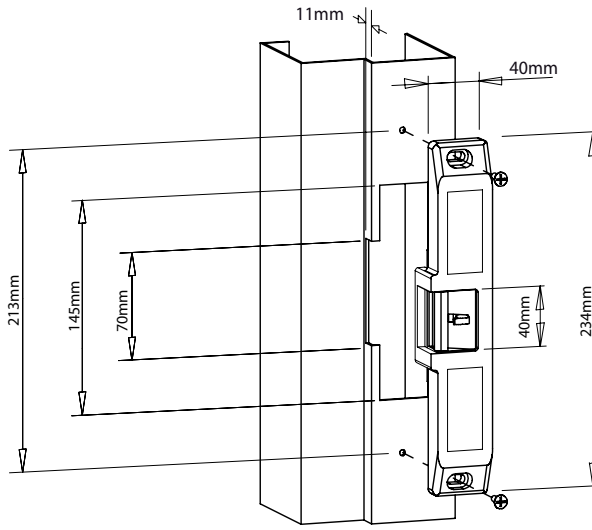

ES2600

Ordering Information

Part Number	Product Description
ES2600-1	ES2600 Panic Bar E/Strike 12Vdc Fail Safe Monitored
ES2600-3	ES2600 Panic Bar E/Strike 24Vdc Fail Safe Monitored

Specification Statement

The strike should be constructed of stainless steel, have a minimum holding force of 650kg and have an endurance rating of 1 million cycles. Maximum penetration into the door frame should not exceed 12mm. The one strike must be changeable from fail safe to fail secure on site where required. The strike should not consume current greater than 175mA at 12Vdc and have a solenoid rated for continuous use. Certifications must include CE and C-Tick.

ES3200 Series Monitored Electric Strike



The Lockwood Padde Series ES3200 series electric strikes are designed for high security applications and manufactured from solid stainless steel.

These long ANSI strikes offer a strong dependable and long-lasting electric strike solution and are suitable for use with any access control system.

These strikes are extremely flexible and can be changed from fail safe to fail secure and mounted on the left or right hand side of the door, thus reducing the amount of variants needed to cover each application.

Key Features

- Fail safe/fail secure changeable on site
- Available in 12Vdc
- 850kg holding force
- 1 million cycles endurance rating
- Stainless Steel locking pins
- Continuously rated solenoid
- 5 Year Tricare Warranty (Padde Series)





Applications

- Timber or metal doors
- Open in/open out doors
- Suitable for use with all access control systems

Product Details

Voltage	12Vdc
Current	175mA @ 12Vdc
Solenoids	Solenoids rated for continuous use.
Monitoring	Solenoid Monitor - 1 amp NO/NC microswitch Door / Latch - 1 amp NO/NC microswitch
Holding Force	850kg Static Strength Rating
Endurance	Cycle tested to 1,000,000 operations
Environment	Operational temperature range -20°C to +60°C
Body	Solid Stainless Steel Construction
Keeper	Stainless Steel
Latch	Suitable for 18mm latchbolt with 3mm door gap

Standards and Compliance

	Approved to UL1034 (highest level)
	CE Approved
	C-Tick Certified
	Anti-Corrosion.

ES3200 Series Monitored Electric Strike

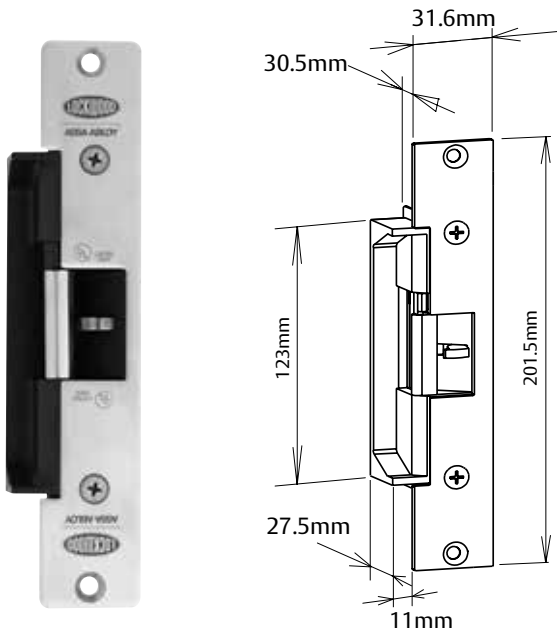

ES3200 Harcor Face Plate Wide Extension Lip

Ordering Information

Part Number	Product Description
ES3200-1	ES3200 E/Strike 12Vdc Fail Safe Non Monitored

Specification Statement

The strike should be constructed of stainless steel, have a minimum holding force of 850kg and have an endurance rating of 1 million cycles. Monitoring must include independent door / latch & solenoid monitoring. The one strike must be changeable from fail safe to fail secure on site where required. The strike should not consume current greater than 175mA @ 12Vdc and have a solenoid rated for continuous use. Certifications must include CE and C-Tick.

ES9000 Series Pre-Load Strike



The Lockwood Padde Series ES9000 has been designed to suit the harshest commercial environments, and has the unique feature of the ability to operate with up to 25kg of pre-load pressure on the keeper. Pre-load is a common condition that is caused by pulling on a door before it unlocks, the weight of warped or drooping doors, seals on fire doors or by differential air pressure created when heating and cooling systems are in use.

Standard features include multi voltage 10 - 30Vdc and field changeable settings from fail safe to fail secure.

Built to last, this is a premium locking solution that has been tested in excess of 2 million cycles and boasts unique features like no other available on the market today.

Key Features

- Operates under pre load up to 25kg
- Easy field selectable fail safe/fail secure
- Multi voltage 10-30Vdc
- 1300kg holding force
- 2.5 million cycles endurance rating
- Latch keeper is significantly quieter in operation
- Weather resistant
- Mounting tabs as standard
- Non handed
- 5 Year Tricare Warranty (Padde Series)
- Weather Resistant (IP54)
- Built in Protection Diode

Applications

- High traffic areas
- Doors subjected to side load (pre load)
- Fire rated door sets
- Open in/open out doors
- Suitable for use with all access control systems

Product Details

Voltage	10 or 30Vdc
Current	250mA @ 12Vdc - 130mA @24Vdc
Solenoids	Solenoids rated for continuous use.
Monitoring	Solenoid Monitor - 1 amp NO/NC microswitch Door / Latch - 1 amp NO/NC microswitch
Holding Force	1300kg Static Strength Rating
Endurance	1,200,000 cycles endurance rating @ 25kg pre-load 2,500,00 cycles general durability without pre-load conditions
Latching	Suitable for 15mm latch with 3mm door gap
Environment	Operational temperature range - 20C to +60C
Body	Solid Stainless Steel Construction
Keeper	Stainless Steel

Standards and Compliance

S3	(Security) Australian Lock Standard (AS4145.2.1993)
D3	(Durability) Australian Lock Standard (AS4145.2.1993)
	Successfully fire rated up to 4hrs on fire door assemblies in accordance with AS1905.1. 2005 (Part 1: Fire resistant door sets)
	CE Approved
	C-Tick Certified
SCEC Approved for Security Level 3	

ES9000 Series Pre-Load Strike

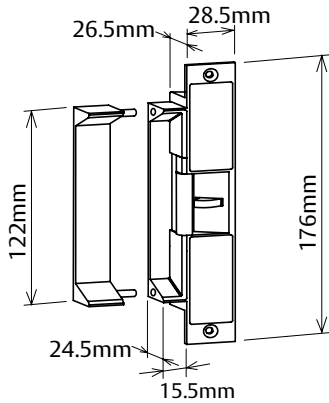

ES9000 with 25mm Extension Lip

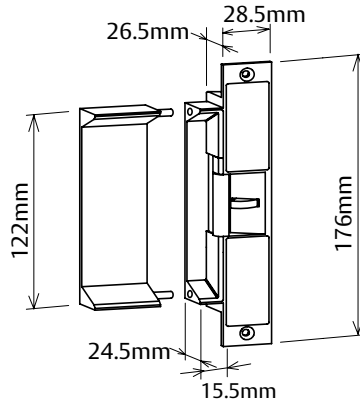

ES9000 with 50mm Extension Lip

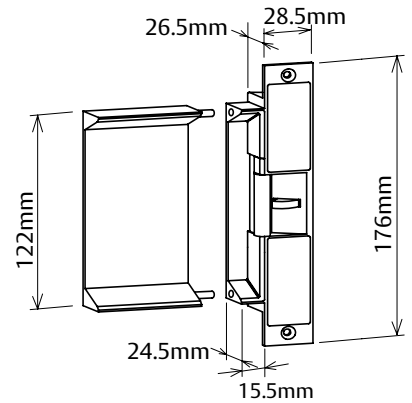

ES9000 with 75mm Extension Lip

Ordering Information

Part Number	Product Description
ES9000	ES9000 E/Strike 12-30Vdc M/Function Preload Monitored
ES9000-010	ES9000 E/Strike 12-30Vdc M/Function Preload Monitored No Lip
ES9000-020	ES9000 E/Strike 12-30Vdc M/Function Preload Monitored 8mm Lip
ES9000-060	ES9000 E/Strike 12-30Vdc M/Function Preload Monitored Lip Holes

Accessories Ordering Information

Part Number	Product Description
210100-541	13mm Rebate Plate
220200-505	25mm Extension Lip (40.5mm total)
220200-506	50mm Extension Lip (65.5mm total)
220200-507	75mm Extension Lip (90.5mm total)
220200-519	Mounting Kit

Note: All ES9000 series electric strikes are supplied in Fail Safe configuration.

Specification Statement

The electric strike should be fully monitored and have independent door / latch and solenoid monitor switches. Holding force for the strike should be not less than 1300kg.

Where Power to Lock and Power to Open functions may be required in the same building, a single electric strike should be interchangeable from either fail safe or fail secure from the rear of the strike.

The electric strike should not consume current greater than 250mA @ 12Vdc and have a solenoid rated for continuous use. A fire rating not less than 4 hours is required where applicable. The strike must be capable of operating with up to 25kg of pre-load pressure applied to the keeper, be tested to 2.5 million operations and carry a minimum warranty of 5 years.

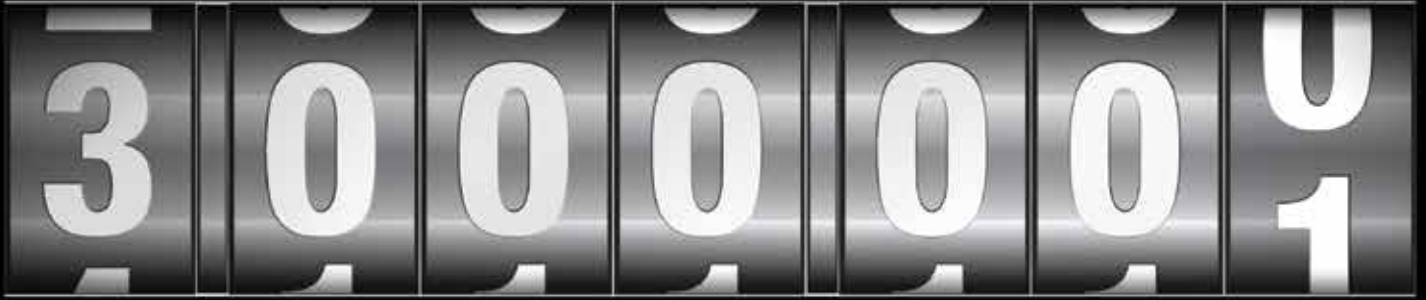

Tested to 3 million cycles... and counting

The ES9000 is approved by the Security Construction and Equipment Committee (SCEC) for Access Control in Secure Areas (Security Level 3).

- Operates under Pre-load up to 25 kg
- Easy field selectable fail safe / fail secure
- Multi voltage 10- 30 Vdc
- Designed and manufactured in Australia





ASSA ABLOY

Lockwood is the leading brand in the Australian locking industry. With an established reputation for high quality products, this iconic brand provides a wide range of locking solutions to residential housing, commercial building and industrial application markets. Lockwood is supported by an extensive distribution and after-sales support network. Our customers include retailers, architects, trade and industrial personnel, locksmiths and security dealers.

ASSA ABLOY is the global leader in door opening solutions, dedicated to satisfying end-user needs for security, safety and convenience.

ASSA ABLOY is represented in all major regions, in both mature and emerging markets, with leading positions in Australia, Europe and North America.



PADDE SERIES

The 5 Year Tricare Warranty

Our belief that we manufacture the finest premium products available in today's market place is backed by the 5 Year Tricare Warranty, ensuring that Lockwood continues to keep Australians safe by delivering security and peace of mind.

For warranty terms and conditions, please visit www.lockweb.com.au or call **1300WARRANTY**

ASSA ABLOY Australia Pty Ltd
235 Huntingdale Road
Oakleigh, Victoria, 3166
Australia

1300 LOCK UP (1300 562 587)
lockweb.com.au

