

GUARD VoIP doorstation mkII

For secure remote access entry.

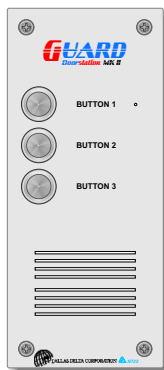

features:

- ✓ remote level control *speaker/microphone*
- ✓ vandal resistant
- ✓ weathershield panel/enclosure *stainless steel*
- ✓ Dedicated VoIP chip set
- ✓ Firmware ungradable
- ✓ Only requiring a 10 base ethernet
- ✓ SIP standard protocol
- ✓ Multi CODEC selection
- ✓ 2 on board relays with unique codes *(optional)*
- ✓ Either relay may be set to in-use function
- ✓ Relay "ON" timer
- ✓ Hands-free up to 1W speaker output *(optional)*
- ✓ Handset model available
- ✓ auto disconnect
- ✓ 2 modes of power over ethernet (PoE)
- ✓ conversation timer
- ✓ all options set via HTTP
- ✓ non volatile memory
- ✓ Asterisk PBX compatibility
- ✓ optional dual line LCD with back light
- ✓ remote relay activation *(door/gate release)*
- ✓ vandal resistant
- ✓ SysLog relayed on events & at set intervals

versatile

easy to use

durable

dependable

The **Guard mkII VoIP Doorstation** is an ethernet connected telephone and provides voice over internet Protocol (VoIP) communication technology. Giving you the power of our PSTN base units in a IP format. Using a SIP protocol standard, it provides an easy connection to most VoIP based equipment. The DoorStation is a loud speaking, hands-free unit. It is well suited for homes, hotels, hospitals and universities as well as many business and commercial settings and providing remote gate access guarding you against unwanted entry onto your property. The **Guard**, making sure your safety and well-being come first!

easy to install:



Installation is made easy thanks to the compact design of the Guard, only a CAT5 cable with PoE is required for operation. The housing allows for trouble free mounting to just about any surface. Programming and setting up of the unit is flexible, either via a remote touch tone phone or using a local keypad *(if fitted)*. Extremely simple instruction sets are used for quick setup.

easy to use:

Configuring your Guard VoIP for the first time is very easy, all IP settings and phone parameters are done by logging on to the units web page, also setting up the call button phone number is done in the same manner. When the above is set the unit will logon to the network and is ready for use.

A call is established by pressing the button and will terminate if the remote end hangs up or the conversation time has elapsed or if the button is repressed during a call. A call made to the unit can be answered by pressing the button or if set to auto-answer, the unit will connect after the preset delay time.

GUARD VoIP doorstation mkII

specifications:

power:	input voltage	9 Volts (<i>minimum</i>) - 50 Volts (<i>maximum</i>)
current consumption:	idle mode on call	60mA @ 13Vdc (0.8 Watts) 100mA @ 13Vdc (1.3 Watts) <i>normally</i> <300mA @ 13Vdc (3.9Watts) (<i>maximum speaker volume 8ohms</i>)
relay contacts:	switching maximum	0.5A @ 60Vdc / 40Vac SELV or TNV voltage free outputs
temperature:	operating range	0°C to +50°C
SPL:	ringer output level speaker output level	>78dBa @ 1 metre (32 steps)
communication:	Ethernet Connection protocol CODECs	10 base SIP G711 (uLaw, aLaw), Speex, iLBC, G726-32 GSM, G.729, G723.1
physical:	panel dimensions (mm) weight (kg)	226.0mm x 100.0mm x 45.0mm 700 grams

enclosure:

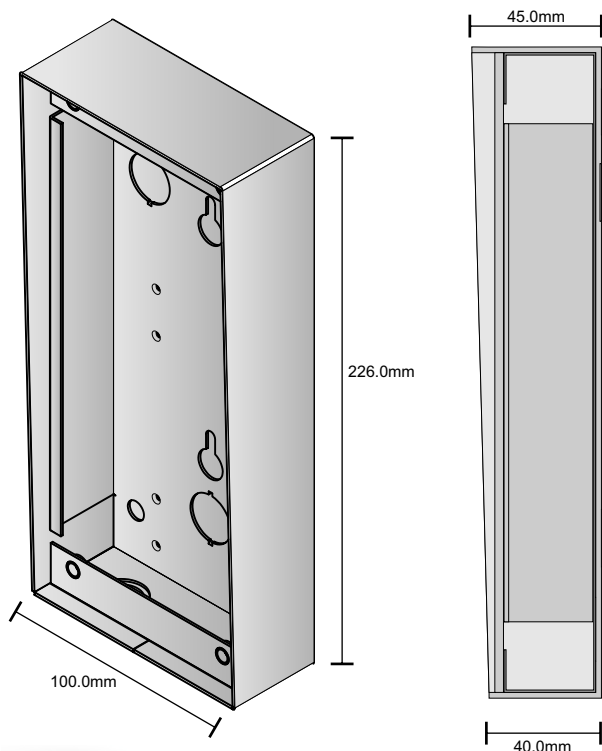

The Guard Doorstation mkII boasts a vandal resistant, robust stainless steel housing. This enclosure is slightly hooded at the top and offers weather-shielding for the toughest of environments. Mounting of your telephone can be easily made to just about any surface thanks to this versatile enclosure.

Dimensions:
226.0mm (height)
100.0mm (width)
45.0mm (depth)

The information contained on this product brochure is subject to change without notice.



designed and manufactured by:

dallas delta corporation *pty. ltd.*



complies with:
ACMA
EN60950
AS/NZS CISPR22
EN55022

All relevant Australian Communications & Media Authority Standards
European Safety Standard
EMI Australia/NewZealand Standard
EMI European Standard (CISPR22)

seadan 
security & electronics

You're in very secure company

VIC Unit 7, 170 Forster Road, Mt Waverley VIC 3149
NSW Unit 5, 142 James Ruse Drive, Parramatta NSW 2150
QLD 15-19 Hudson Road, Albion QLD 4010
WA Unit 4, 200 Balcatta Road, Balcatta WA 6021
ACT Unit 2, 157-161 Gladstone Street, Fyshwick ACT 2609

1300 366 851 | seadan@seadan.com.au

20170125

