

DHU13815 (DH-PFA162)

Housing Bracket



Features

- Neat & Integrated design.
- Material: Aluminum.
- Housing Bracket.
- Support three-axis rotation for housing installation.

Technical Specifications

Model	DH-PFA162
General	
Material	Aluminum
Dimension (W x H x D)	115mmx115mmx98.8mm(4.53"x4.53"x3.89")
Weight	0.5kg(1.1lb)
Load Bearing	6.0kg(13.23lb)
Color	White
Operating Temperature	-40°C ~60°C(-40°F ~140°F)
Humidity	0~90% RH
Applicable Model	PFH610N/V/A series housing

Order Information

Type	Part Number	Description
Camera mount	DH-PFA162	Housing bracket _ Dahua brand
	PFA162	Housing bracket _Neutral, no brand

Dimensions (mm/inch)

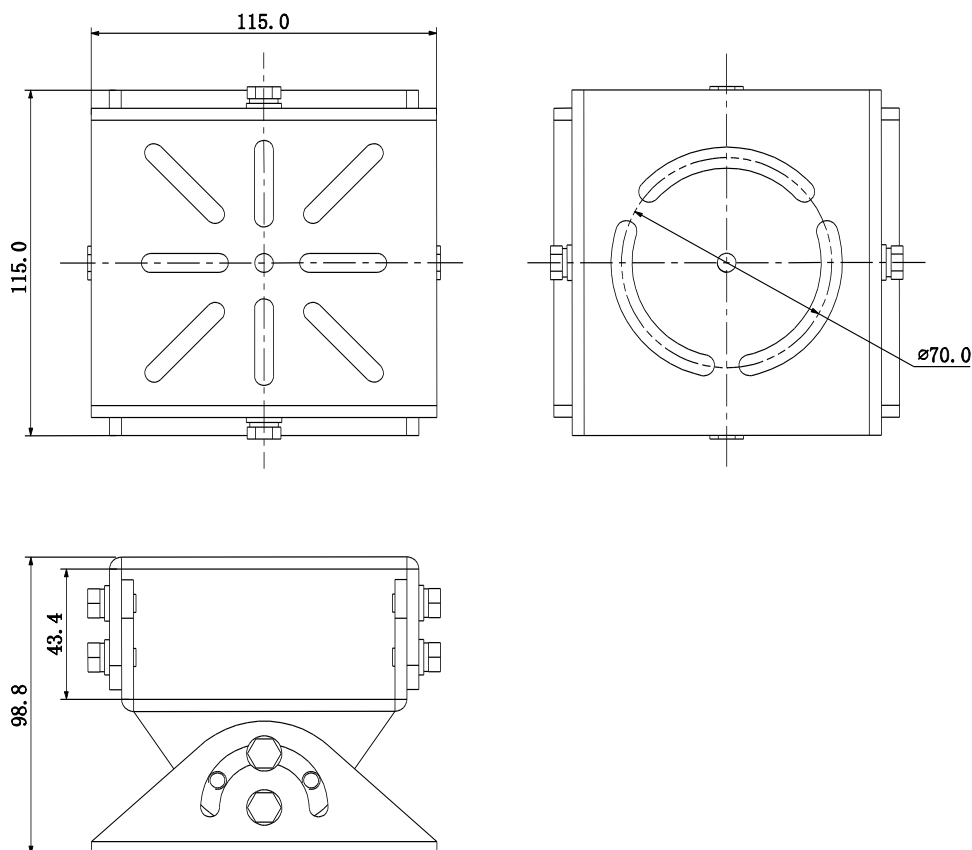

seadan
security & electronics



YOU'RE IN VERY
SECURE COMPANY

VIC Unit 7, 170 Forster Road, Mt Waverley VIC 3149
NSW Unit 5, 142 James Ruse Drive, Parramatta NSW 2150
QLD 15-19 Hudson Road, Albion QLD 4010
WA Unit 4, 200 Balcatta Road, Balcatta WA 6021
ACT Unit 2, 157-161 Gladstone Street, Fyshwick ACT 260

1300 366 851 | seadan@seadan.com.au