

PCR43308R, PCR43308SS

8-Channel, 433MHz Penta Receiver with Frequency Hopping

Features

- Multiple relay output modes
- Frequency hopping between 433.10 to 434.70MHz
- Unlimited remotes can be programmed to the receiver
- Compatible with PentaFOB® and PentaCODE® remotes
- Diagnostic LED's to indicate power and relay activation
- Wide operating supply voltage and low current consumption
- Two versions available
 - PCR43308R- relay output
 - PCR43308SS- open collector output

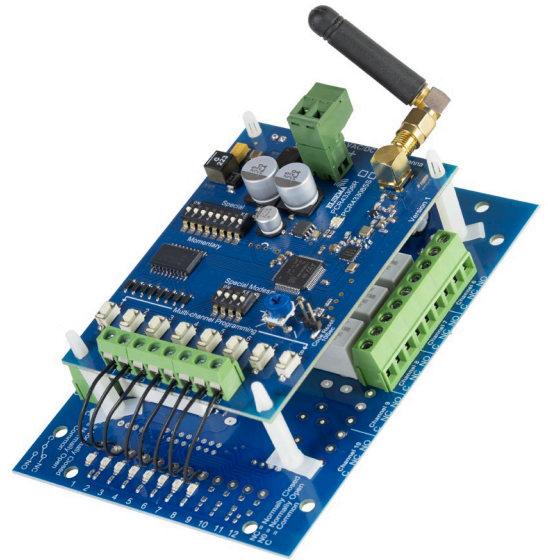

Applications

- Tilt-tray tow trucks
- Concrete pump trucks
- Water cart trucks in mining sites
- Warehouse automation i.e. Roller doors, cooler room doors, forklifts
- Home automation i.e. garden lights, swimming pool control etc.
- Security, lighting and automotive controls and anywhere else you need a wireless signal to transmit a contact closure

Description









The PCR43308R and PCR43308SS receivers are packed with features and designed to deliver exceptional flexibility. It offers multiple operating modes, which can be easily selected via two sets of dip switches. The remote-control programming process is highly versatile, allowing for either multi-channel programming or individual button assignment to specific relay outputs.

Users can configure multiple buttons to control a single relay output or assign a single button to activate multiple relay outputs, enabling tailored functionality for a wide range of applications. It is recommended to carefully read the user manual and familiarize yourself with the receiver's operating modes.

<p>PCR43308R 8 Channel receiver with 8 relay outputs.</p>	<p>PCR43308RE PCR43308R receiver in an enclosure.</p>	<p>PCR43308SS 8 Channel receiver with 8 open collector outputs.</p>

Output Modes

The 8-way Mode Switch is assigned to each of the eight outputs. When the mode switch is ON, the operation of the respective output is selected via the 4-way Special Mode Switch. When the mode switch is OFF, the respective output is in momentary operation.

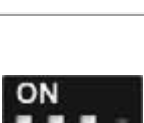
		8-Way Mode Switch ON	8-Way Mode Switch OFF
	All OFF	Latching: Outputs alternate at every correct incoming signal.	Momentary: Output is ON only while correct signal is received.
	1 ON	Security Latching: Outputs will be on until supply to receiver is momentarily interrupted. Similar to fire alarms.	Momentary: Output is ON only while correct signal is received.
	2 ON	Delayed OFF: Output stays ON for 1-300 seconds, adjustable by trimpot.	Momentary: Output is ON only while correct signal is received.
	1 & 2 ON	Delayed ON: Output comes ON after 1-10 seconds, adjustable by trimpot.	Momentary: Output is ON only while correct signal is received.
	3 ON	Single Output Latched: only one output is ON at a time.	Single Output Momentary: only one Output is ON while correct signal is received.
	1 & 3 ON	Instant OFF: Same as Delayed OFF except output will switch OFF as soon as the transmitter input is deactivated.	Momentary: Output is ON only while correct signal is received.
	2 & 3 ON	<p>ON-OFF:</p> <p>Ch 1 => Relay 1 ON Ch 2 => Relay 1 OFF Ch 3 => Relay 2 ON Ch 4 => Relay 2 OFF Ch 5 => Relay 3 ON Ch 6 => Relay 3 OFF Ch 7 => Relay 4 ON Ch 8 => Relay 4 OFF</p>	Momentary: Output is ON only while correct signal is received.
	1,2 & 3 ON	Timed Latching: Outputs alternate at every correct incoming signal or switch off after the delayed time whichever occurs first. The delayed time is 1-300 seconds, adjustable by the trimpot.	Momentary: Output is ON only while correct signal is received.
	1,2,3,4 ON	Latching Test Mode: Use the Program Button to test outputs.	Momentary Test Mode: Use the Program Button to test outputs.

Customised Software

Custom output modes can be programmed to do special functions. Call Elsema for more details.

Technical Data

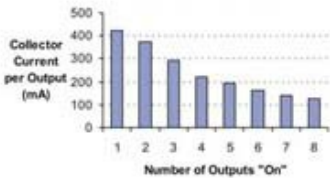
	PCR43308R	PCR43308SS
Supply Voltage	12 – 24 Volts AC or DC. (Recommended powerpack: 12PP-1000)	
Standby Current	15 mA stand by at 24VDC	
Current Consumption	91 mA with all relays “ON”	
Frequency Band	433.100 to 434.700MHz	
Operating Temperature Range	-5 to 50°C	
Receiver Memory Storage	Unlimited Remotes	
Decoding System	Encrypted 17 billion code combinations	
Outputs	8 change over relay outputs, rated at 10 Amps 240VAC each.	 <p>Chart indicates that eight outputs can be ON simultaneously with each output current being 125mA. Outputs can hold 40 Volts in “Off” state.</p>
Relay Contacts	Common (C), Normally Closed (NC) & Normally Open (NO)	
Antenna	ANT433 series	
Dimensions	130 X 94 X 55 mm	95 X 70 X 27 mm
Useable Transmitters	PentaFOB® series and PentaCODE® series	

Programming Instructions

Multi-Channel Programming

This method programs all buttons on the remote control to the receiver in a single step.

To perform multi-channel programming:

1. Press and hold program buttons 1 and 8 on the receiver.
2. Press button 1 on the remote control for 2 seconds.
3. Release the button on the receiver and the remote control.

Suitable for simultaneous transmission which allows multiple buttons to work at the same time.

Single-Channel Programming

This method allows the user to program each button of the remote control to a specific channel on the receiver. Each button can be assigned to multiple relay outputs, or multiple buttons can be used to activate a single relay. The receiver has 8 program buttons, each corresponding to a specific relay output.

To program a single channel:

1. Press and hold the program button for the desired relay.
2. Press the remote control button to be programmed, for 2 seconds.
3. Release the button on the receiver and remote control.

Suitable for channel interlocking which allows only a single button to work at a time.

Shorting the Code reset pins for 10 sec will delete all the remotes from the receiver’s memory.

Block Diagram

PCR43308R

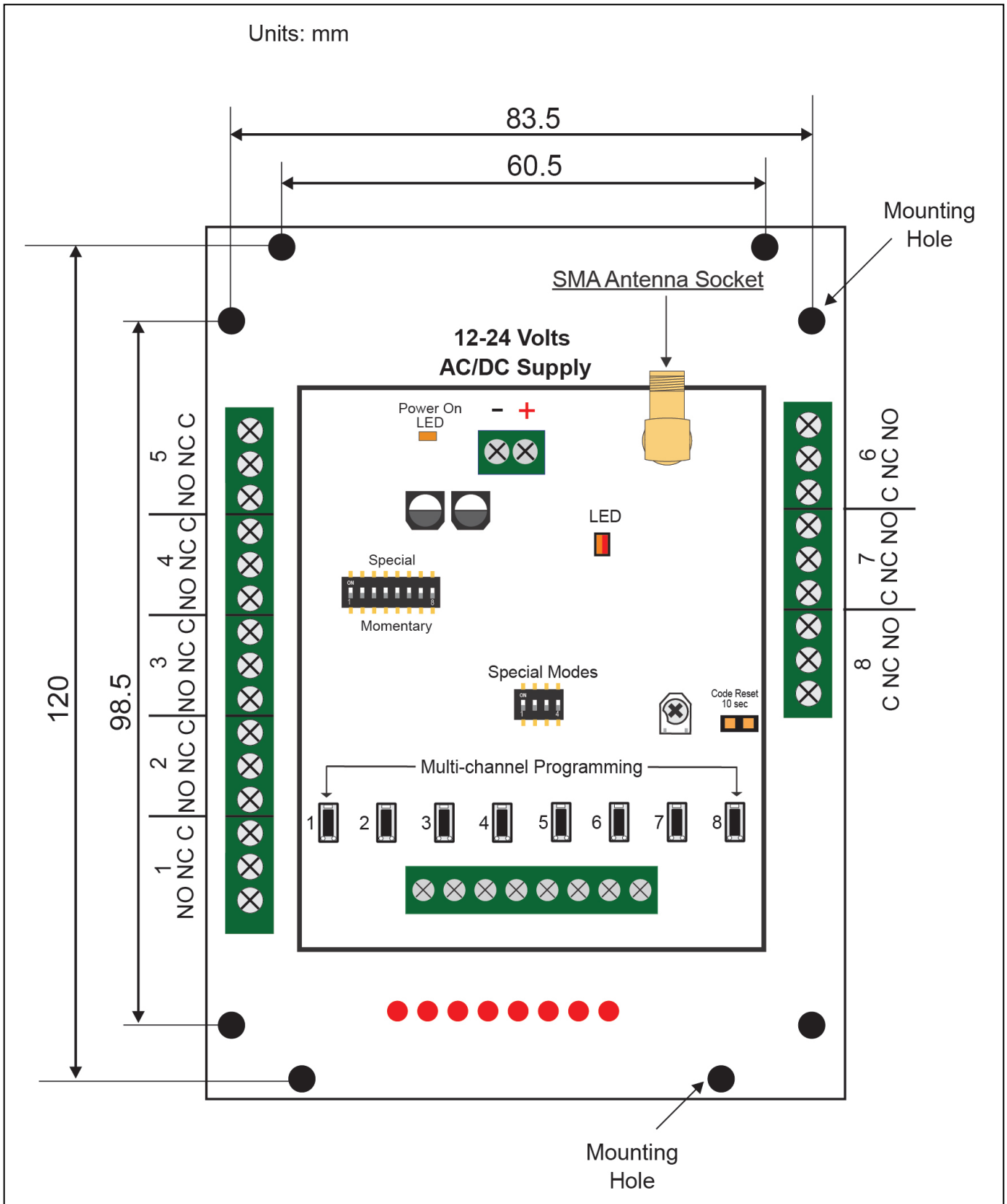

PCR43308SS

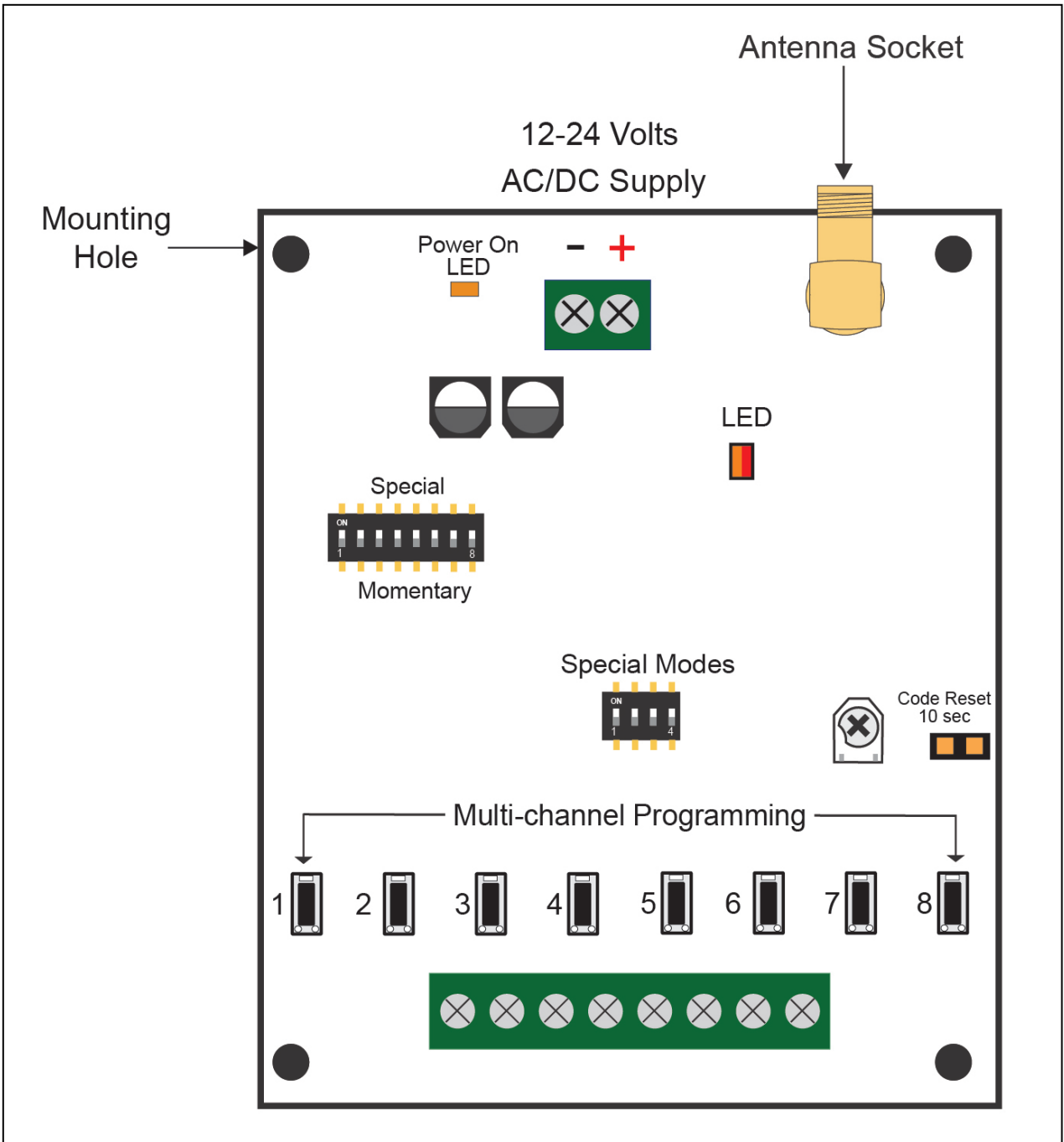

Application Notes

Care should be taken with the solid-state outputs that they are protected from inductive loads. This is done by connecting diodes across your DC inductive load.

Inductive loads such as DC relays must be clamped with a diode across the relay coil. If this is not done the spikes generated by the DC relay can lock-up the receiver. When a lock-up occurs, you will need to remove the power and re-connect it.

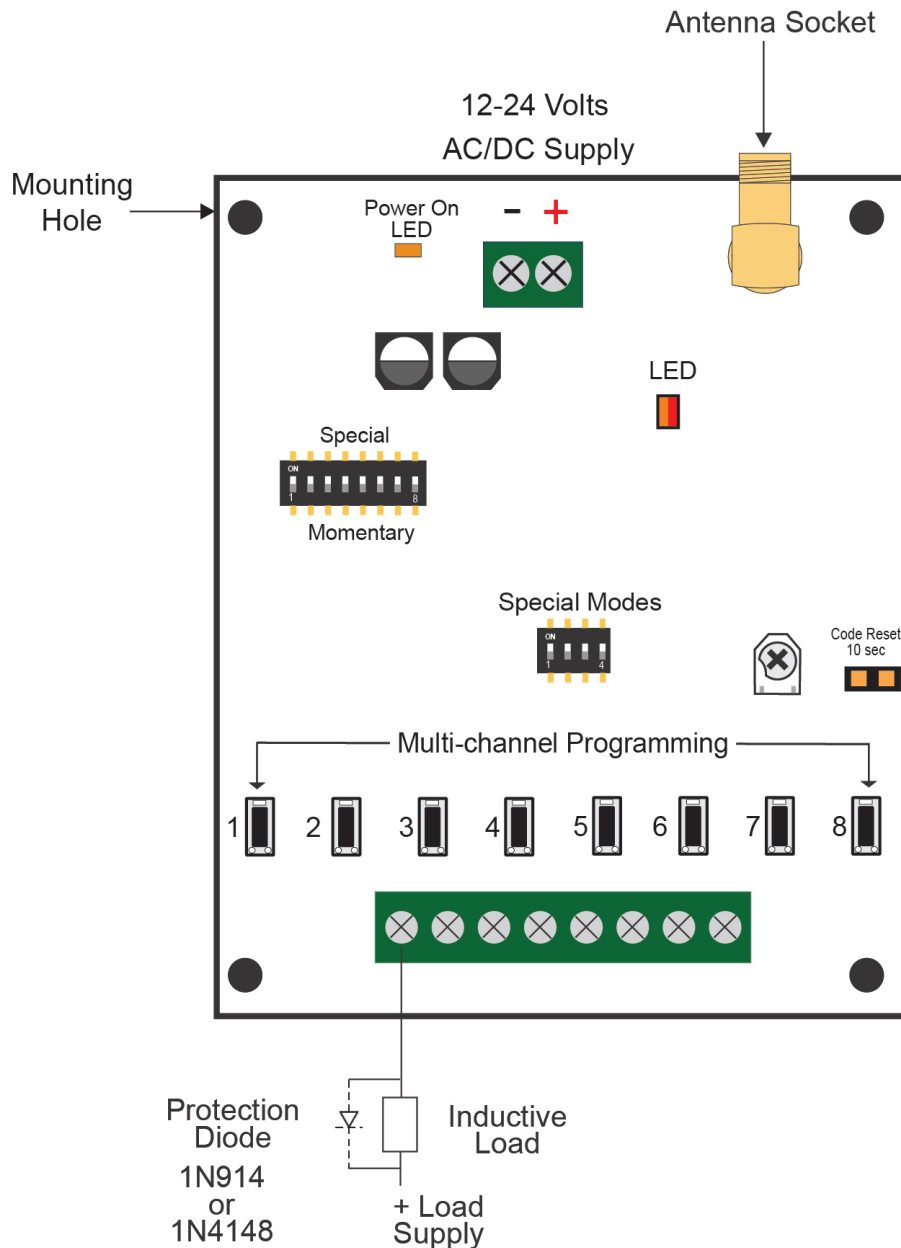

Manufactured by

Elsema Pty Ltd
31 Tarlington Place, Smithfield
NSW 2164, Australia.
Ph: 02 9609 4668
Website: <http://www.elsema.com>