

PRODUCT 35000 SERIES
HEAVY DUTY MAGNETIC DOOR HOLDER FIRE RATED



PRODUCT DESCRIPTION

Heavy duty fire and smoke door magnetic holder, with 40kg holding force, titanium alloy surface finished, elegant appearance. Installed on fire and smoke doors in projects where doors are required to be held in the open position for both pedestrian and general traffic, the devices have to be linked into a buildings fire/smoke alarm system.

When an alarm occurs, power is removed from the devices and the doors are returned to the closed condition, preventing the spread of fire and/or smoke to other areas. The devices are fire tested to a rating of 4 hours and are supplied either 12 or 24VDC.

35000 SERIES

TECHNICAL DETAILS

PART NO.	35772	
DESCRIPTION	Heavy duty floor mount door holder box, cream colour	
TYPE OF MOUNT	Floor mount	
SIZE	D= 67.5 x W= 115 x H= 84mm	
PART NO.	35770	35771
FUNCTION	Heavy duty flush mount magnetic door to suit standard electrical box. Or Floor mount with 35772 box	
HOLING FORCE	Up to 40kg	
VOLTAGE/CURRENT	12VDC/100mA	24VDC/50mA
SIZE	D= 50 x W= 74 x H= 115mm	

PRODUCT FEATURES

- Fire rated
- Up to 40kg holding force
- 12 and 24VDC options
- Floor mount and wall mount options
- 2 year warranty

PRODUCT DIMENSIONS AND INSTALLATION

FLOOR MOUNT BOX 35772

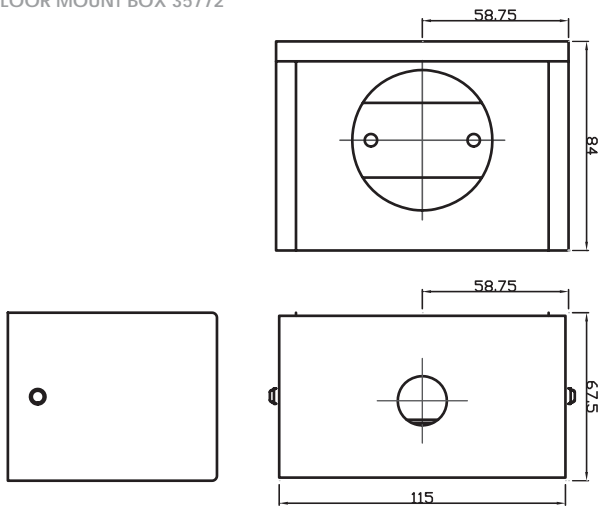

WALL MOUNT 35770 & 35771

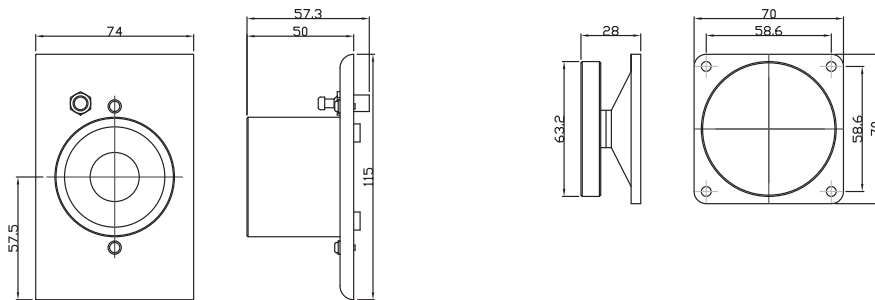

TYPE OF INSTALLATION

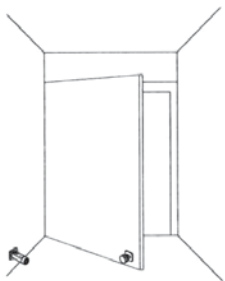

Extension Wall Mounting

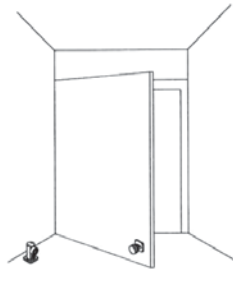

Floor Mounting

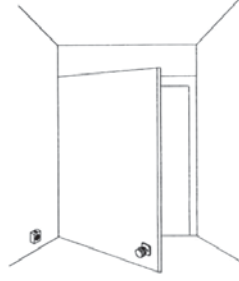

Wall Mounting