

3500 SERIES

HEAVY DUTY MAGNETIC DOOR HOLDER



The 3500 Series of magnetic door holders are specifically designed for fire and smoke doors with a 40kg holding force and titanium alloy surface finish. Elegant in appearance, this series is ideal for projects where doors are required to be held in the open position for both pedestrian and general traffic, the devices have to be linked into a buildings fire/smoke alarm system.

When an alarm occurs, power is removed from the devices and the doors are returned to the closed condition, preventing the spread of fire and/or smoke to other areas. The devices are fire tested to a rating of 4 hours and are supplied either 12 or 24VDC.

Technical Details

Part No.	35772
Function	Heavy duty floor mount door holder box, cream colour
Type of Mount	Floor Mount
Dimensions	D=67.5 x W=115 x H=84mm

Part No.	35770	35771
Function	Heavy duty flush mount magnetic door to suit standart electrical box or Floor mount with 35772 box	
Holding Strength	Up to 40kg	
Voltage/Current	12VDC/100mA	24VDC/50mA
Dimensions	D=50 x W=74 x H=115mm	

Product Features

- Fire rated (contact Allegion for more details)
- Up to 40kg holding force
- 12 and 24VDC option
- Floor mount and wall mount options
- 2 year warranty

Product Dimensions and Installation

FLOOR MOUNT BOX 35772

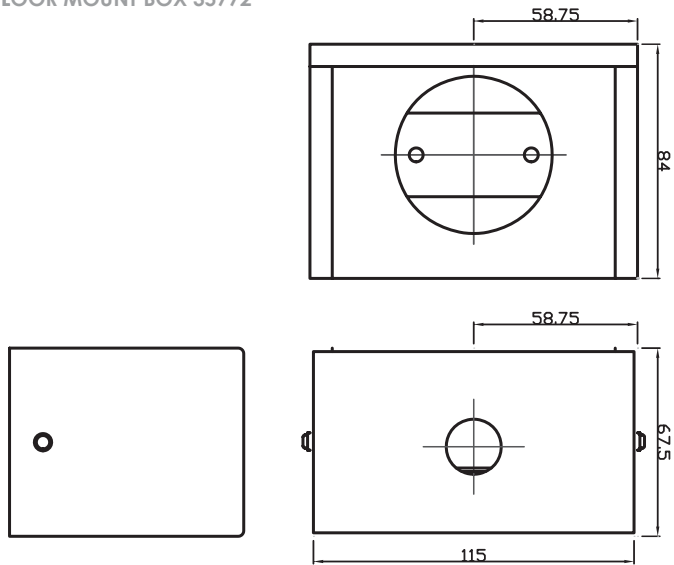

WALL MOUNT 35770 & 35771

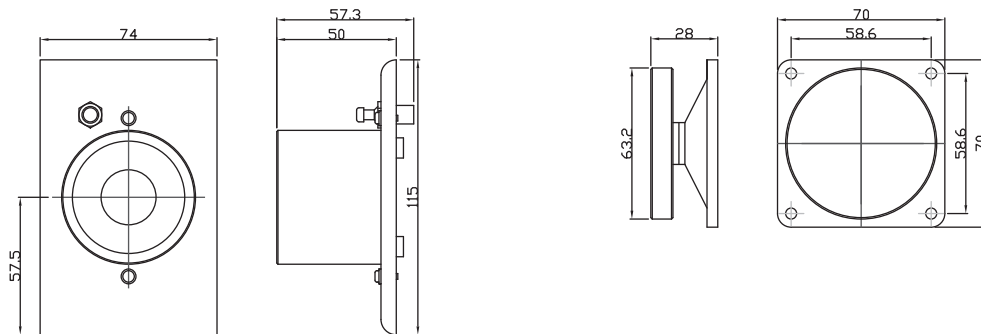

TYPE OF INSTALLATION

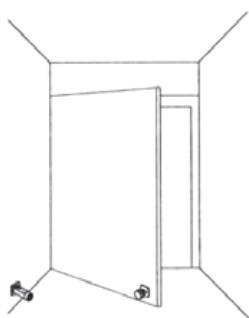

Extension Wall Mounting

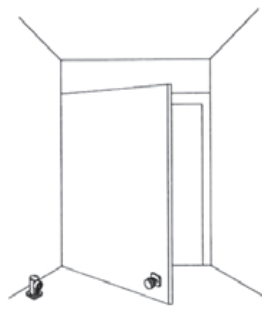

Floor Mounting

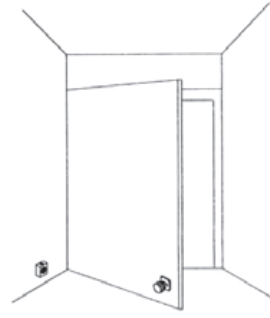

Wall Mounting