



INSTALLATION MANUAL

FES110 HIGH SECURITY ELECTRIC DEAD-LOCK STRIKE

1. INTRODUCTION

The FES110 series dead - lock electric door strike release mechanism has been designed to provide door access control while maximising security to a door assembly fitted with square bolt deadlocks.

The FES110 monitors both door lock tongue and internal locking of the strike. The device is supplied Power to Lock (PTL) or Power to Open (PTO) and cannot be changed, and operates in 12 - 24VDC multi-voltage mode. Product comes with a 2 year warranty. The device is manufactured in FSH's Sydney operation.

2. FEATURES

Installed into the door frame, the FES110 operates in conjunction with a mechanical high security deadlock. The dead bolt of the mechanical door lock is captured by the strike keeper when locked and is held securely until the strike receives an access or release signal from the access control system. The keeper then swivels out and remains in this position until the door is closed and the mechanical dead bolt re-engages with the keeper, pushing it back into the locked position.

Monitoring functions include strike keeper status –DSS- (deadlock engaged) and lock status sensor –LSS- (strike securely locked).

Product now includes a multi-voltage power saving circuit board.

3. Technical Data

PART NO.	FES110 PTL - 12-24VDC	FES110PTO - 12-24VDC
FUNCTION	Power to Lock	Power to Open
HOLDING STRENGTH	Up to 500kg.	
VOLTAGE/CURRENT	12 - 24VDC (Multivoltage) 12V 600mA dropping to 220mA, 24V 350mA dropping to 120mA	
APPROVALS	2 hour fire rated	
MONITORING	Lock bolt and Locking Solenoid	
SIZE	L=306 x W=32 x H=58mm	

4. Dimensions

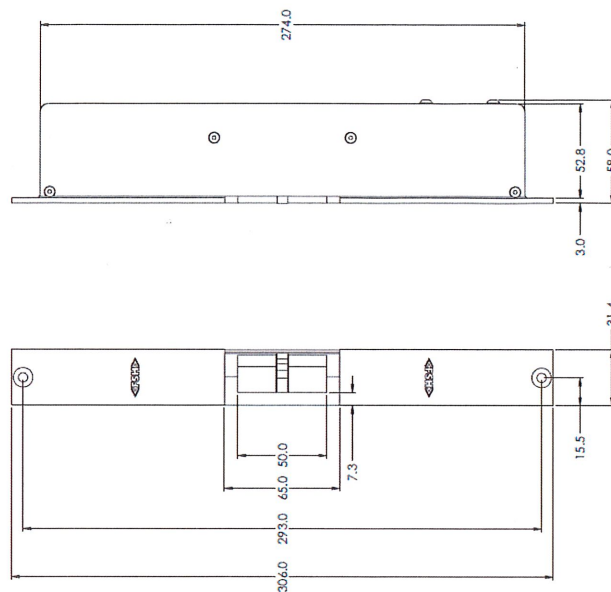

5. Wiring Diagram

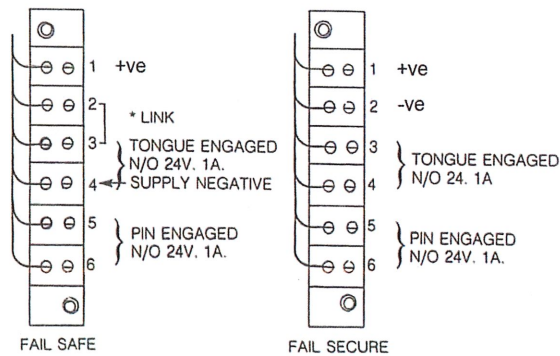

6. Power Saving Feature

The FES110 – 12-24V now includes a multi-voltage circuit board which eliminates the requirement to order a specific voltage.

The board also features a “power saving” feature which reduces the current consumption.

In fail safe mode current required to lock the door (i.e operate the solenoid) is 600mA reducing to 220mA 12VDC. Current loads at 24VDC are 350mA and 120mA.

In fail secure mode the current required to open the door (i.e operate the solenoid) is 600mA reducing to 220mA 12VDC. Current loads at 24VDC are 350mA and 120mA.

In both cases the current drops once the solenoid operates.