

# CCW30F

Flush Mount Electro Magnetic MINI Lock Non Monitored

## CCW30F DESCRIPTION



The **LOX CCW30F** Flush Mount Electro Magnetic Mini Lock was designed for securing small sliding door cabinets and the like. The holding force is up to **180kg**.



## CCW30F

FLUSH MOUNT MONITORED SINGLE ELECTRO MAGNETIC LOCK

## SPECIFICATIONS

CCW30F	FLUSH MOUNT SINGLE ELECTRO MAGNETIC LOCK NON MONITORED
HOLDING STRENGTH	UP TO 180KG, TESTED TO 400.000 CYCLES
VOLTAGE/CURRENT	DUAL VOLTAGE 12/24VDC 12VDC = 350mA 24VDC = 175mA
APPROVALS	CE & C-TICK  
ENVIRONMENTAL	OPERATIONAL TEMPERATURE RANGE - 20 DEG. C TO 60 DEG. C.

**LOX**  
LOCKING

LOX LOCKING PTY LTD | [www.loxlocking.com.au](http://www.loxlocking.com.au)

**LOX**<sup>®</sup>

# CCW30F

Flush Mount Electro Magnetic MINI Lock Non Monitored

## PRODUCT DIMENSIONS

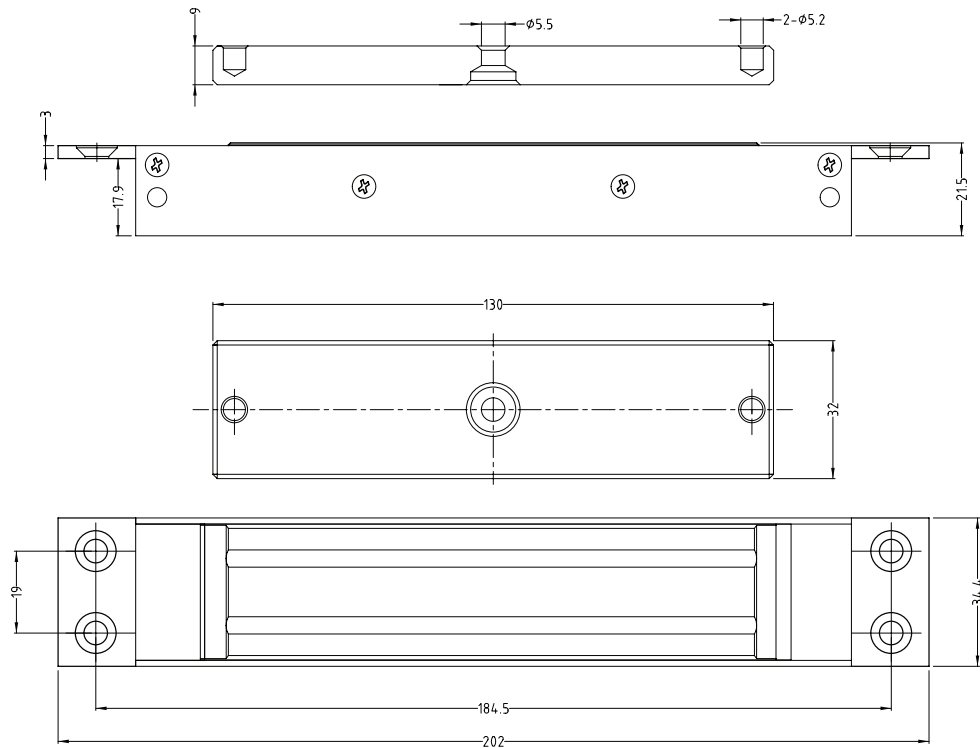

Dimensions (mm)

## CCW30F FACTS

- Built-in varistor (MOV) surge protection
- CE/RCM Approvals
- Lifetime warranty
- No residual magnetism

**LOX**  
LOCKING

LOX LOCKING PTY LTD | [www.loxlocking.com.au](http://www.loxlocking.com.au)

**LOX**<sup>®</sup>