

	REVISED	DRAWN	APPROVED
①	AMENDED RATING LABEL	GARY 28/05/08	SUNNY 28/05/08
②			

NOTES:

- 1.DC CORD:18AWG 1.8M Lead Free
- 2.DC PLUG SET TO C+
- 3.CASE:BLACK

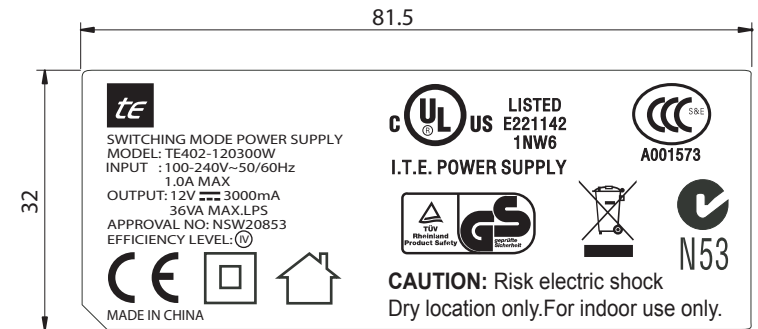
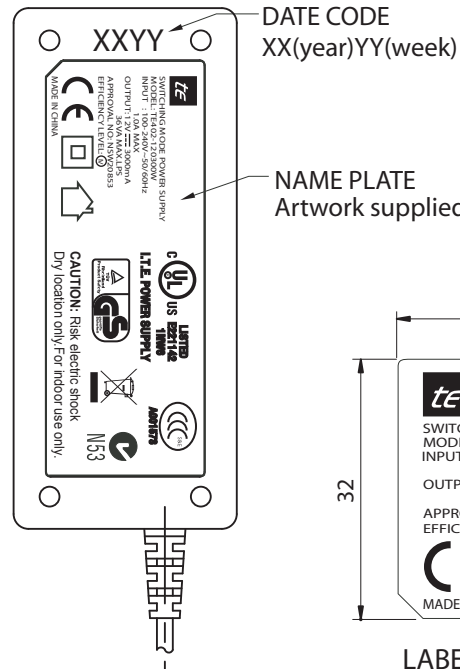
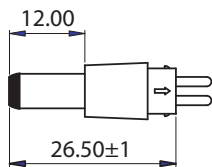
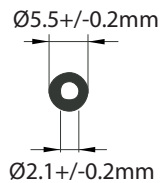
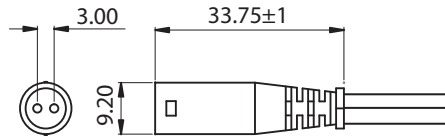

LABEL ARTWORK
Black words on silver base label

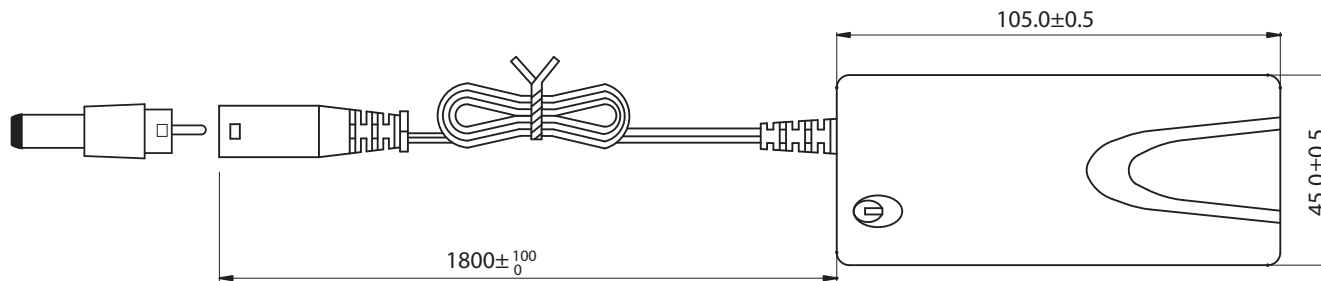

TOLERANCE +/-0.2

TE DRAWING NO:TE-7443 R1					PART NO: 12VDC3000/1		
DESCRIPTION: SWM IN LINE 2.1 REVERSIBLE							
DATE	23/04/08	SCALE	NTS	CHECKED	SUNNY 24/04/08		SHEET 1 OF 2
SIZE	A4	DRAWN	GARY	APPROVED	BRIAN 24/04/08		
UNIT	MM	CUSTOMER SIGNATURE:					DATE:



THIS DRAWING AND SPECIFICATIONS ARE THE PROPERTY OF TELEPHONE EQUIPMENT (NSW) Pty Ltd AND SHALL NOT BE REPRODUCED OR USED IN ANY MANNER WITHOUT THE PRIOR WRITTEN CONSENT OF TELEPHONE EQUIPMENT (NSW) Pty Ltd

	REVISED	DRAWN	APPROVED
①	AMENDED RATING LABEL	GARY 28/05/08	SUNNY 28/05/08
②			

SHIPPING MARKS:

DESCRIPTION:SWM IN LINE 2.1 REVERSIBLE
 PART NO:12VDC3000/1
 COLOUR:BLACK
 MEASUREMENTS:42X28.0X23.5CM
 QTY: 60 PCS
 GW:
 P/O:
 MADE IN CHINA

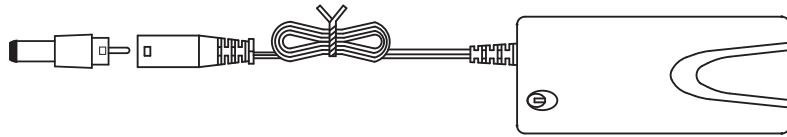

1PC/WHITE BOX

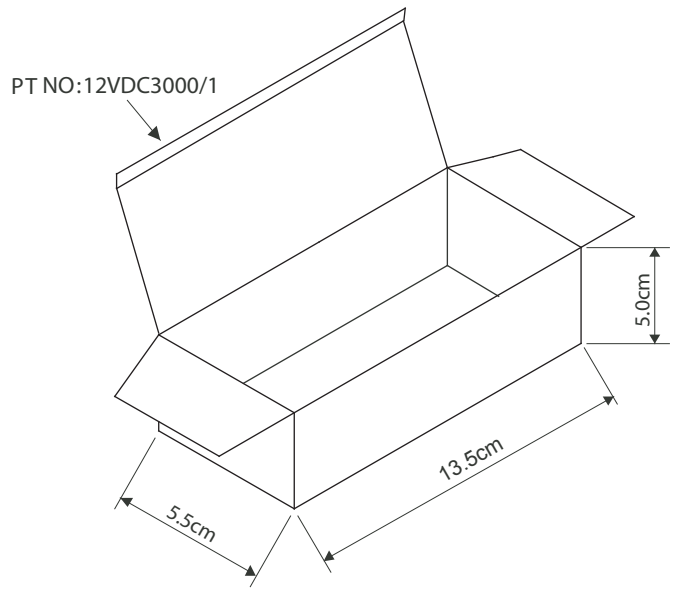

WHITE BOX

P/O:
 PTNO.:12VDC3000/1
 DESC.:SWM IN LINE 2.1 REVERSIBLE
 QTY.: PCS
 G.W.: KGS
 MEAS.:42X28.0X23.5CM
 DATE:

60 WHITE BOXES/CARTON

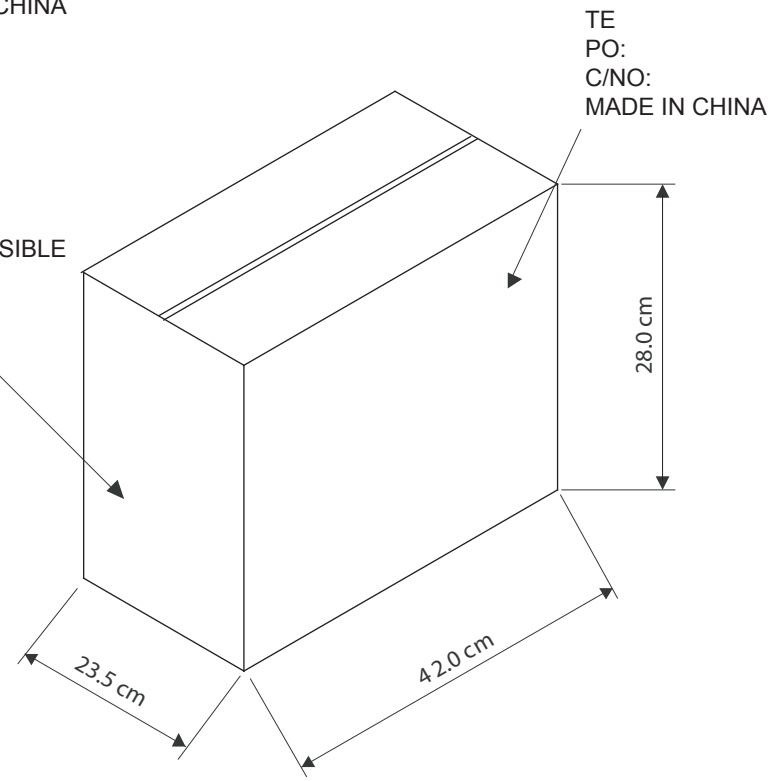

CARTON

TOLERANCE +/-0.2

TE DRAWING NO:TE-7443 R1					PART NO: 12VDC3000/1			
DESCRIPTION: SWM IN LINE 2.1 REVERSIBLE								
DATE	23/04/08	SCALE	NTS	CHECKED	SUNNY 24/04/08		SHEET 2 OF 2	
SIZE	A4	DRAWN	GARY	APPROVED	BRIAN 24/04/08			CUSTOMER:TE
UNIT	MM	CUSTOMER SIGNATURE:					DATE:	



THIS DRAWING AND SPECIFICATIONS ARE THE PROPERTY OF TELEPHONE EQUIPMENT (NSW) Pty Ltd AND SHALL NOT BE REPRODUCED OR USED IN ANY MANNER WITHOUT THE PRIOR WRITTEN CONSENT OF TELEPHONE EQUIPMENT (NSW) Pty Ltd