

# ARLSWP-23G/R

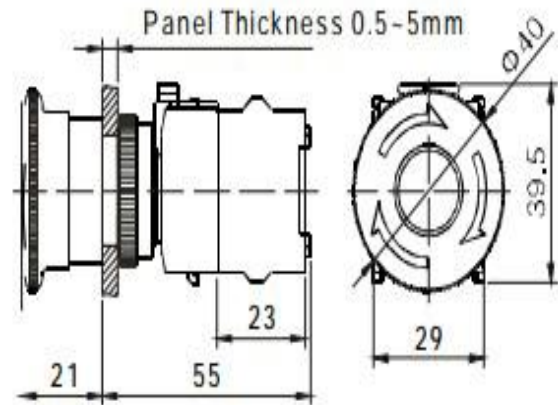

70mm x 115mm



## Specification

Operating Temperature		-25°C ~ +55°C(no freezing) keep the air flowing around the illuminated pushbutton
Operating Humidity		45 - 85%RH(no condensation)
Contact Resistance		≤50mΩ
Insulation Resistance		≥100MΩ
Dielectric Strength		3000 V, AC 50Hz
Vibration Resistance		50Hz,Amplitude 1.0mmp-p
Shock Resistance		≥10g
Life	Mechanical	Momentary type:≥1,000,000 times; Alternate type and selector type:≥500,000 times Key-lock type and emergency type:≥200,000times
	Electrical	≥50,000 times
Terminal		Thread connection, diameter of welded wire: 2 x 1.5mm maxConnecting link:6.3 x 0.8mm
Operating Force		800gf-2200gf, according to the quantity of switch units