

ARLSWP-47

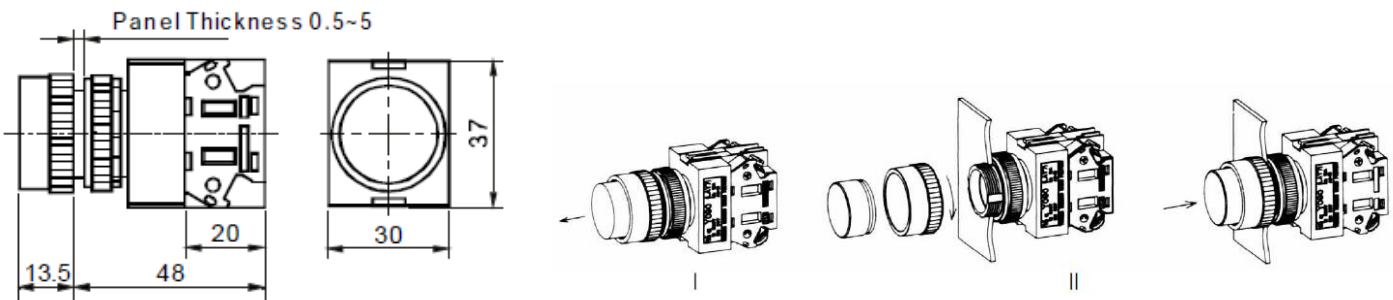
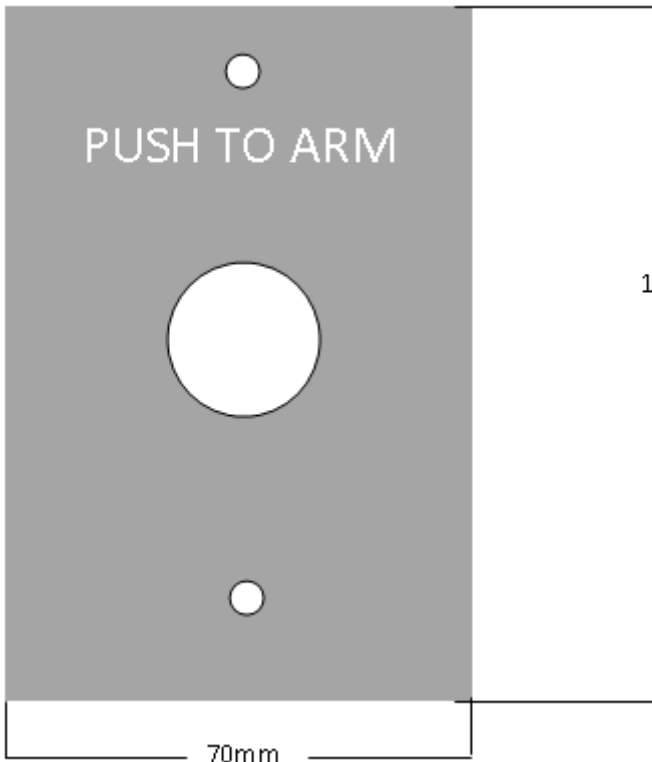

Rated Insulation Voltage	Ui: 660V					
Terminal Current	Ith: 10A					
Rated Voltage	24V	48V	110V	220V	380V	500V
Direct Current	10A	5A	2.2A	1.1A		
Alternating Current P.F=0.7			10A	6A	4A	2A

Operating Temperature	- 25°C ~ +55°C(no freezing)	
Operating Humidity	45 ~ 85%RH(no condensation)	
Contact Material	<ul style="list-style-type: none"> - silver - silver alloy - gold-clad silver, cladding thickness is 3 μ m 	
Contact Resistance	≤ 50m Ω	
Insulation Resistance	≥ 100MΩ	
Dielectric Strength	3000 V,AC50Hz	
Vibration Resistance	50Hz,Amplitude 1.0mm p - p	
Shock Resistance	≥ 10g	
Life	Mechanical	Momentary type: ≥ 1,000,000 times. Alternate type,selector type: ≥ 500,000times. Key-lock type, emergency type: ≥ 200,000 times.
	Electrical	≥ 50,000 times
Terminal	Thread connection,diameter of welded wire: 2 × 1.5mm max Connecting link:6.3 × 0.8mm	
Operation	Operating Force:800gf~2200gf (according to the quantity of switch units) Operating Travel:About 5.5mm(Pushbuttons)	