

# ARLSWP-50R/G

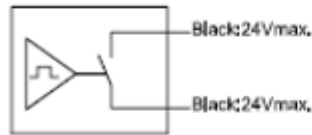

Wiring Diagram

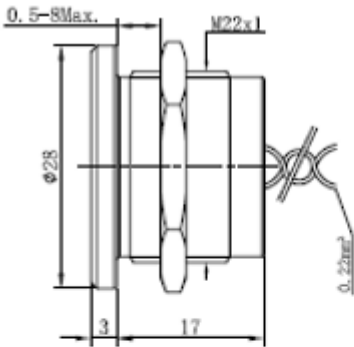
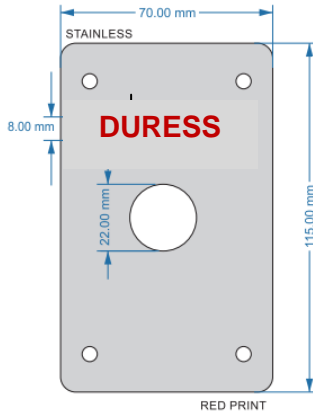
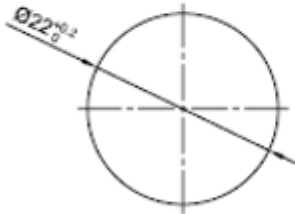

PANEL CUTOUT  
MAX.PANEL THICKNESS  
8 mm

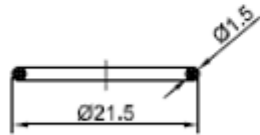

Seal Ring

Part Number: PS223P10Y ◆ 1

## SPECIFICATIONS:

- 1.Switch Operation: Momentary NO (Pulse) ;
- 2.Max.Switch Rating- 200mA 24VAC/DC;
- 3.Operation Life- 50 Million cycles;
- 4.Wiring: AWG 26, Length 300mm;
- 5.IP Class: IP68/IP69K,
- 6.Operating Temperature: -40℃ ~ +75℃;
- 7.Operating Force: About 2~6N.

## MATERIALS:

- 1.Body: Al Alloy.