

# TAKEX PHOTOELECTRIC BEAM SENSOR

PXB-100ATC-KH: 330ft (100m)

## Instruction Manual

Thank you for purchasing this product.

Read this instruction manual before using the product to make sure that you use it correctly.

This product is designed to be installed into the housing (sold separately) for use. Make sure to install this product into the housing for use.

This device is an opposed type photoelectric beam sensor that consists of a photo transmitter that transmits infrared light, and a photo receiver for the transmitted light, as shown in the illustration on the right.

The infrared light transmitted from the transmitter expands in a cone shape, while the light beams enter the receiver.

The straight line that connects the transmitter with the receiver is the detection line.

This model is designed to prevent a crawling intrusion to coverage area by means of OR-gated detection in addition to AND-gated detection.

In order to ensure that the detection line has sufficient margin of sensitivity, adjust the direction of the light beams before placing the system into operation. Providing sufficient margin of sensitivity reduces the occurrence of malfunction caused by dense fog, heavy rain, frost, snow, and other such weather conditions.

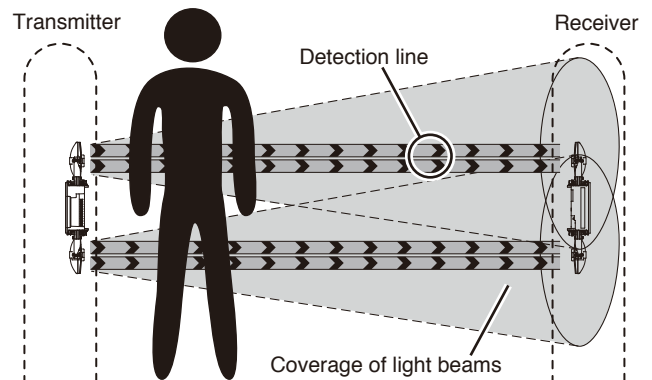

## Main Features

### (1) ANTI-CRAWL DETECTION



Upper and lower beam individually detects the objects and issues a signal only by blocking each beam.

### (2) AT · HF SEPARATE OUTPUT



AT output : OR-gated by upper and lower beam.  
HF output : AND-gated.

### (3) SYNCHRONIZED HIGH POWER BEAM



By synchronizing the timing of transmitting and receiving beam, the stacking system will be more reliable.

### (4) DOUBLE MODULATION



Double modulated beams are designed to distinguish the true beam signal from accidental or deliberate interference from sunlight, car headlights and other artificial light sources. This increases the reliability in the outdoor security system.

### (5) QUAD HIGH POWER BEAM



The beam power is 100 times of the minimum requirement. The beam distance is 10 times of the described specification. This high power beam also realizes the reliability against the harsh conditions like fog, snow, heavy rain.

### (6) ECOLOGY



RoHS adapted - Environment friendly. Free from Lead, Mercury, Cadmium, Hexavalent chromium, Polybrominated biphenyl, Polybrominated diphenyl ether.

### (7) LOW CURRENT CONSUMPTION



30% less than current models. The low current consumption reduces cabling costs.

### (8) DUAL RING SIGHT



Enables better and clear view for easy beam alignment.

### (9) TARGET COLOR



The vivid color of the internal structure can be recognized easily from the far end in the beam alignment procedure.

The color differs between a transmitter and a receiver which helps easy installation and checking.

### (10) INCREASED RANGE ADJUSTMENT ALLOWANCE



Vertically  $\pm 20^\circ$  compared with previous version. It may adapt to the slope installation flexibly.

### (11) WIRELESS ALIGNMENT CHECKER



Enables easy and accurate beam alignment. (Sold separately)

### (12) LIGHTNING PROTECTION



Minimizes the damage caused by induced lightning through wiring.

# — TABLE OF CONTENTS —

1	PRODUCT COMPONENTS		6	WIRING METHOD	
1-1	PARTS DESCRIPTION .....	2	6-1	POSITION AND RATING OF TERMINALS .....	11
1-2	ACCESSORIES .....	2	6-2	WIRING DISTANCE .....	11
1-3	NAMES OF OPERATION SECTION .....	3	6-3	WIRING DISTRIBUTION DIAGRAM (WIRING DIAGRAM)..	12
2	OPERATING PRECAUTIONS		7	OPTICAL AXIS ADJUSTMENT	
2-1	EXAMPLE OF INCORRECT INSTALLATION .....	4	7-1	NAMES AND FUNCTIONS OF OPTICAL AXIS ADJUSTMENT PARTS .....	14
3	BEFORE USE		7-2	OPTICAL AXIS ADJUSTMENT USING THE ALIGNMENT MECHANISM.....	15
3-1	PROTECTION DISTANCE AND RANGE OF LIGHT BEAM COVERAGE .....	5	8	OPERATION CHECK .....	19
3-2	MOUNTING HEIGHT .....	5	9	EXPLANATION OF FUNCTIONS	
3-3	OPTICAL AXIS ADJUSTMENT RANGE .....	5	9-1	AUTO GAIN LOCK FUNCTION .....	20
3-4	TERM DESCRIPTION .....	6	9-2	UPPER/LOWER CHANGEOVER FUNCTION .....	20
3-5	APPLICATIONS .....	6	9-3	LED LIGHT TURN-OFF FUNCTION .....	20
4	INSTALLATION METHOD		9-4	PROGRAMMABLE AGC FUNCTION .....	21
4-1	INSTALLATION INTO HOUSING .....	9	9-5	EXTERNAL ENVIRONMENT DIAGNOSTIC FUNCTION ...	21
5	INITIAL SETTING		9-6	ALARM LED .....	21
5-1	MODULATION FREQUENCY CHANGEOVER .....	9	9-7	LIGHT SENSITIVITY SIGNAL FUNCTION.....	21
5-2	SYNCHRONIZED TIMING .....	9	9-8	FUNCTION SETTING CHECK .....	21
5-3	MASTER / SLAVE SELECTION .....	9	9-9	ALIGNMENT WIRELESS CHECKER CONNECTION FUNCTION .....	21
5-4	BEAM POWER SELECTION .....	10	10	TROUBLESHOOTING.....	22
5-5	ALARM OUTPUT SWITCH .....	10	11	SPECIFICATIONS .....	22
5-6	ENVIRONMENTAL OUTPUT SWITCH .....	10	12	EXTERNAL DIMENSIONS .....	23
5-7	RESPONSE TIME .....	10	13	OPTIONAL .....	23
5-8	SOUND CHECK .....	10			

## 1 PRODUCT COMPONENTS

This section describes the contents of the product package and the names and functions of the parts that appear in this instruction manual.

### 1-1 PARTS DESCRIPTION

Check that the following transmitter, receiver, and accessories are included in the box when you first unpack the product.

**Sensor body** : 2 pcs (Transmitter: 1 pc, Receiver: 1 pc)

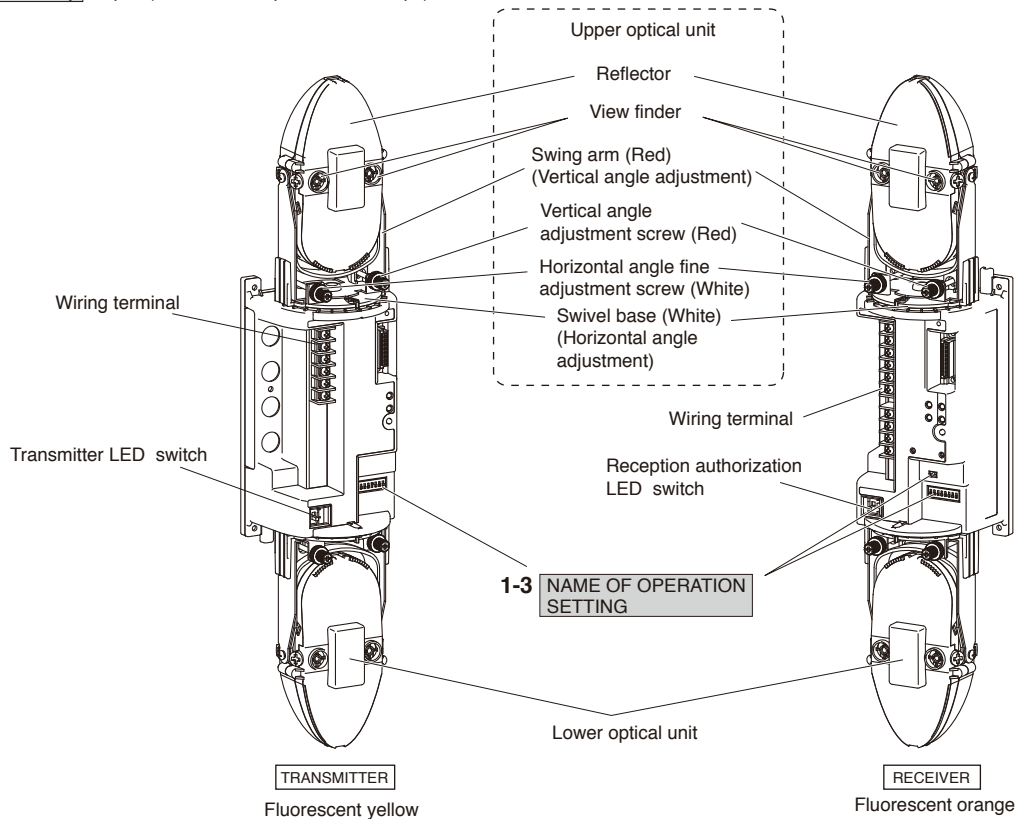

### 1-2 Accessories

 Panhead screw  
(M3×12mm)  
: 8 pcs

 Instruction Manual  
(This Manual)  
: 1 pc

# 1-3 NAMES OF OPERATION SECTION

## [Transmitter]

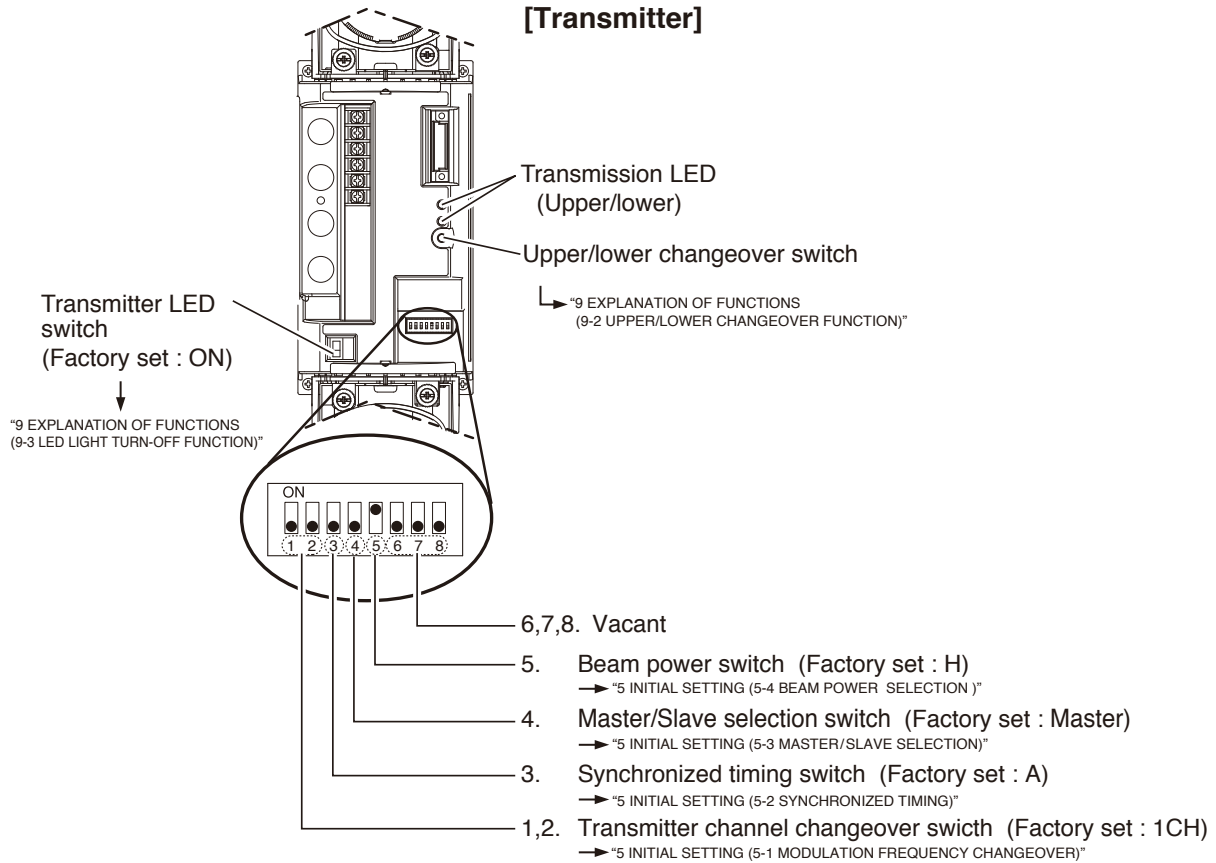

## [Receiver]

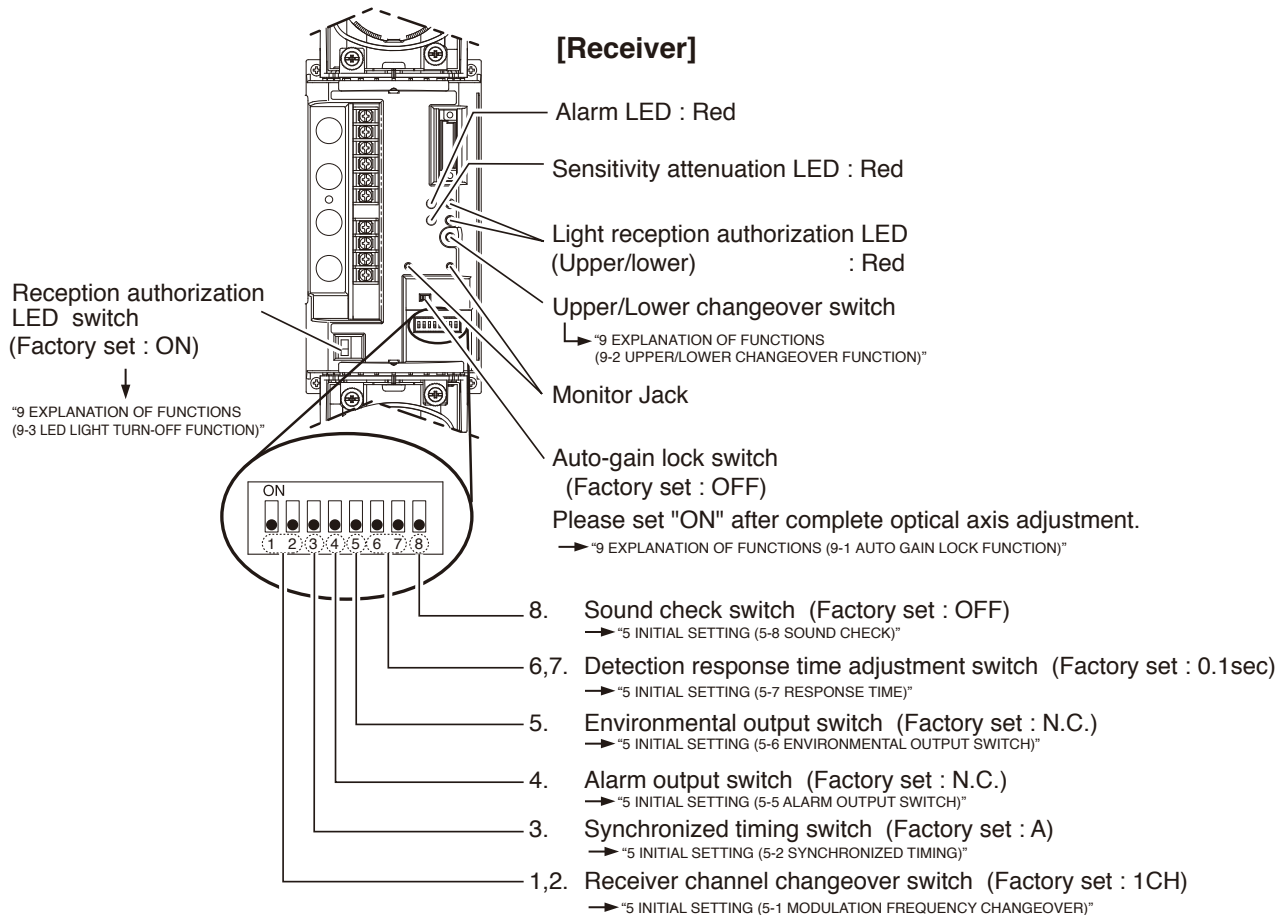

# 2 OPERATING PRECAUTIONS

• This manual describes the precautions to be observed for safe operation of this device by classifying them into the following categories. As these are important, be sure to read and strictly observe them.

- (1) When using multi-level protection, use sensors of the same model for both upper and lower sensors, and set the same transmission power (H/L) for all of them.
- (2) Using these sensors together with sensors from a different series (e.g. PB-IN-HF) may cause interference between the sensors.

## Description of the Display

 **Warning** Indicates information that if ignored and the device is handled incorrectly, may result in death or serious injury.

 **Caution** Indicates information that if ignored and the device is handled incorrectly, may result in injury or damage to property alone.

 This symbol indicates a prohibited action, with the specific action shown near the symbol. **Example:**  Do not disassemble

 Indicates the useful information.

## Warning

 Do not use the sensors powered with a voltage level other than the indicated power supply voltage specified (between 10 to 30V DC). Doing so may cause a fire or electrical shock.

 Do not connect a device that exceeds the capacity shown to the output contact of this device. Doing so may cause a fire or electrical shock.

 Do not touch the terminal section with wet hands. Doing so may cause an electrical shock.

 Do not disassemble or modify this device. Doing so may cause a fire, electrical shock, or malfunction of the device.

 If smoke or an abnormal odor or sound is found, leaving it unattended may cause a fire or electrical shock. Immediately turn off the power to the device and confirm that the abnormal state has been corrected, and then ask the place of purchase for repair.

## Caution

 Do not install this device in a location that cannot support its weight. Doing so may cause the device to fall and cause an injury or malfunction of the device.

## 2-1 EXAMPLE OF INCORRECT INSTALLATION

 **DON'TS** Do not install as shown below. This will cause erroneous detection or detection failure.

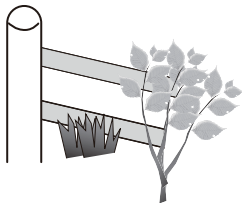

● Installation in locations shaded by trees etc.

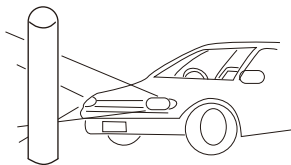

● Installation in location where strong light such as sunlight or light from vehicle headlights can directly enter the receiver

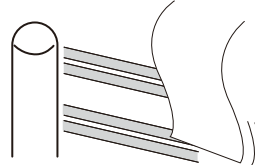

● Installation in areas where objects that move with the wind (the laundry etc) can obstruct the optical axis



● Using PXB-100ATC-KH together with other models (Except PBX-100HF-KH)

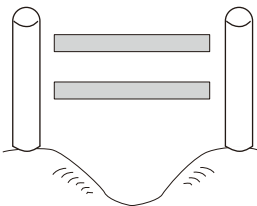

● Installation on uneven ground

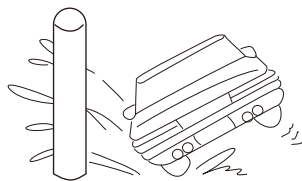

● Installation in locations where the unit may be splashed by dirty water or direct sea spray

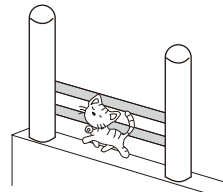

● Installation directly above a wall

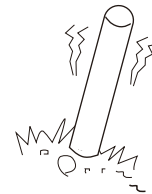

● Installation in an unstable, wobbling location

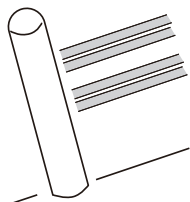

● Slanted installation

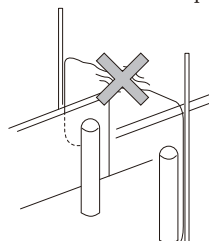

● Overhead wiring

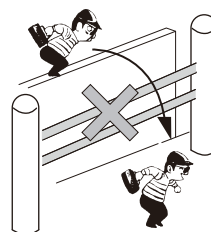

● Installation close to a wall



## Cautions when using the outdoor photoelectric beam sensor (Daily maintenance)

1. In areas where there are trees or weeds, the infrared may get obstructed by overgrown branches or leaves. As this may cause erroneous detection, be sure to trim down leaves and branches according to the growth of the plants. Furthermore, the infrared may get obstructed by swaying branches or leaves due to wind. Keep in mind the swaying of leaves and branches when trimming them.
2. Vine type plants may wrap around the photoelectric beam sensors causing erroneous detections. Therefore, be sure to prune such plants regularly.
3. Other natural phenomena such as insects or bird droppings may soil the sensors causing miss detection. Be sure to clean the sensors regularly.

# 3 BEFORE USE

In order to use these sensors correctly, thoroughly read this instruction manual and select the mounting position and protection distance.

## 3-1 PROTECTION DISTANCE AND RANGE OF LIGHT BEAM COVERAGE

As the infrared light leaves the transmitter, it expands into conic shape light beams. The optical axis is in the center of the light beams. Arrange the reflector so that the device on the opposite side is in the center of the light beams.



If the optical axis (center of the light beams) is aligned correctly, a detection line with sufficient margin of sensitivity is formed.



If the optical axis is not aligned correctly, there will be insufficient margin of sensitivity even if the receiver is at the center of the light beams, making the system more susceptible to adverse effects of the environment resulting in a malfunction.

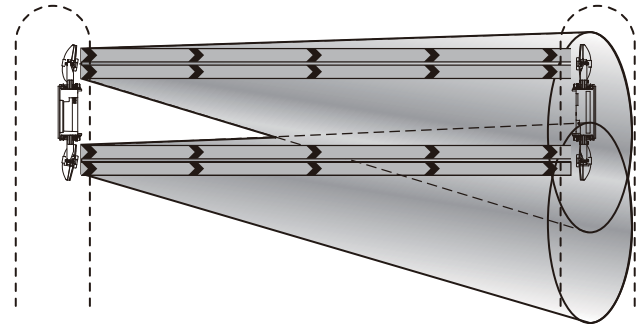
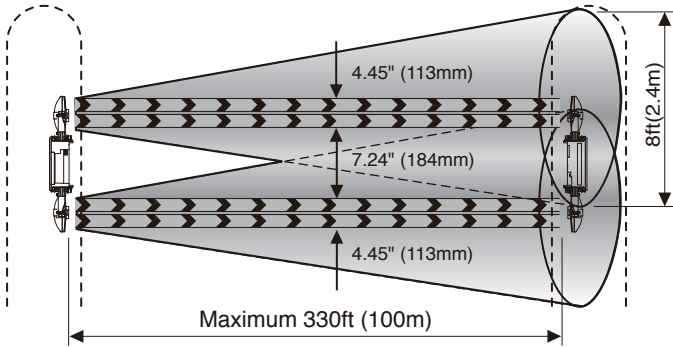

## 3-2 MOUNTING HEIGHT

As these sensors are designed to detect humans, install so that the center of the sensors are at a height of approximately 2.6ft (0.8m) from the ground when installing both on a wall and on a pole.

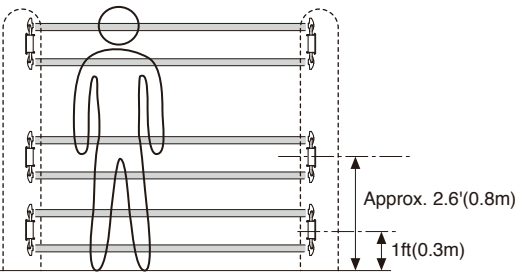

Installing so that the center of the sensor is approximately 2.6ft (0.8m) from the ground means that the protection line is at waist height for humans, enabling reliable detection.



If the installation position is too high or too low, the protection line will be above shoulder height or below knee height, making it more difficult for reliable detection.

● Stacking : In order to prevent the intrusion by crawling or climbing over, stack PXB-100ATC in several numbers.

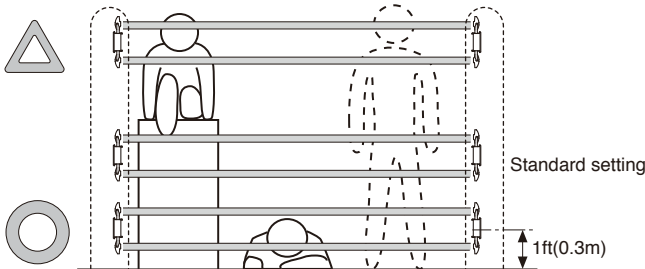

Set the sensor about 1ft(0.30m) from the floor so that it will detect the head of crawling person.



To prevent a intruder from climbing over the standard setting beams, set the sensor at the height upper than standard setting.

## 3-3 OPTICAL AXIS ADJUSTMENT RANGE

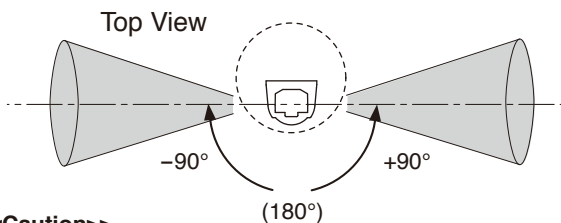

Side view

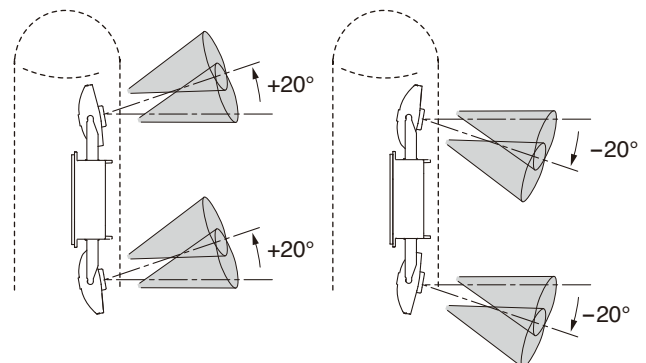

### <<Caution>>

The optical axis may be shielded depending on the shape of the housing and mounting surface.

Check the optical axis range carefully and start installation before use.

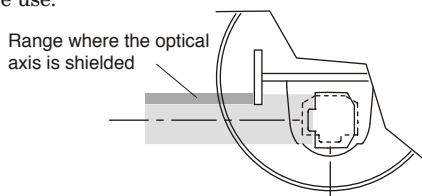

### 3-4 TERM DESCRIPTION

● This manual uses the following terms for explanation. Refer to the terms and their meanings.

- Channel (CH)** : Frequency channel of the infrared beam signal. (There are four channels from 1CH to 4CH)
- Synchronized signal** : A signal emitted from the synchronized output of the master, which is the reference signal to determine the timing for transmitting and receiving the infrared beams.
- Master** : A device to output the synchronized signal, which is used as a reference to determine the timing for transmitting and receiving the infrared beams. (Only the transmitter can be set as the master.)
- Slave** : A device to transmit or receive the infrared beams based on the input synchronized signal. (The receiver operates as the slave.)
- Synchronized timing** : Timing for transmitting and receiving the infrared beams based on the synchronized signal. You can select from two types of timing, A and B. Change the synchronized timing in the same channel to achieve the multi-level protection.
- Synchronized wire** : A wire to transfer the synchronized signal from the master to the slaves.

### 3-5 APPLICATIONS

#### Single stacking

- A** Set the transmitter and receiver to the same channel
- B** Set the transmitter and receiver to the same synchronized timing
- C** Set the transmitter as a master
- D** Connect the synchronized units by wire

\* Synchronized wire is necessary for even single stacking.

\* Please note that there is an electric polarity in a synchronized wire.

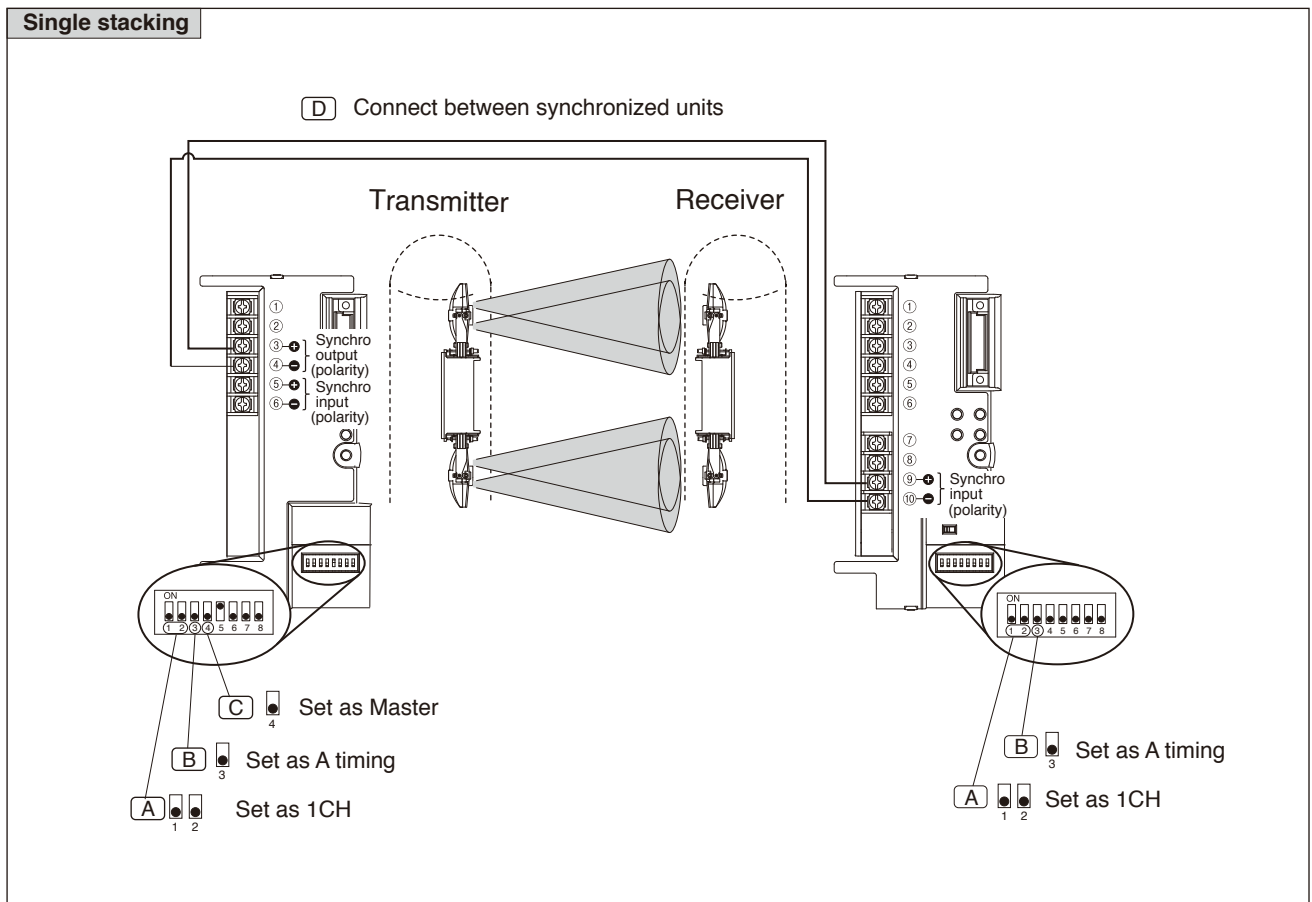

## 2 level stackings

### ● 1st beam setting (Same as single stacking)

- A** Set the transmitter and receiver to the same channel
- B** Set the transmitter and receiver to the same synchronized timing
- C** Set the transmitter as a master
- D** Connect the synchronized units by wire

### ● 2nd beam setting

- E** Set the transmitter and receiver to the same channel as 1st beam
- F** Set the transmitter and receiver to the different synchronized timing from 1st beam
- G** Set the transmitter as a slave
- H** Connect the synchronized units by wire
- I** Connect the synchronized units by wire

• Please note that there is an electric polarity in a synchronized wire.

## 2 Level Stacking Application

**D** Connect between synchronized unit

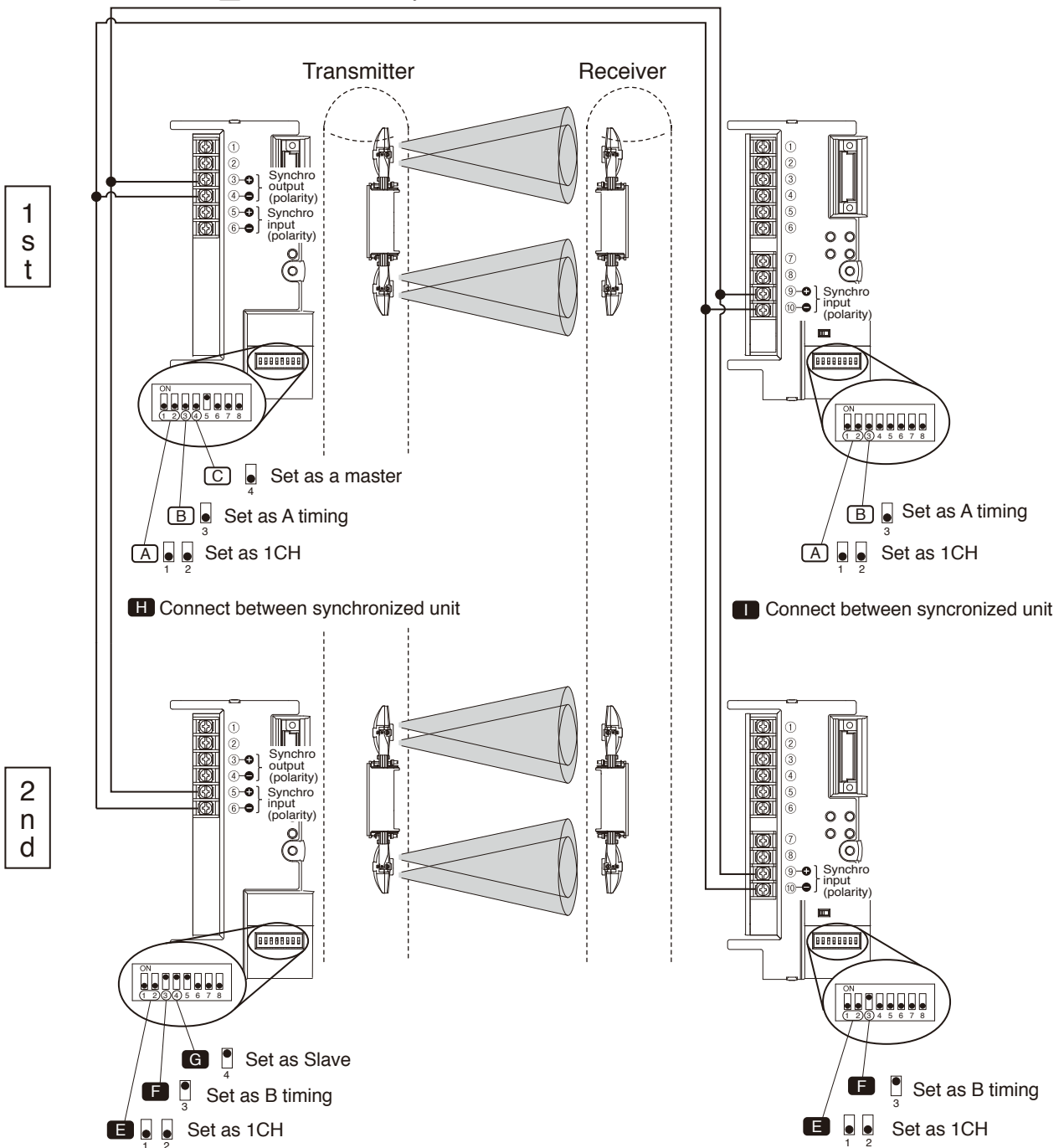

● **Triple level stacking**

Avoid setting the neighboring number of channel in the same direction. (Like 1CH and 2 CH)

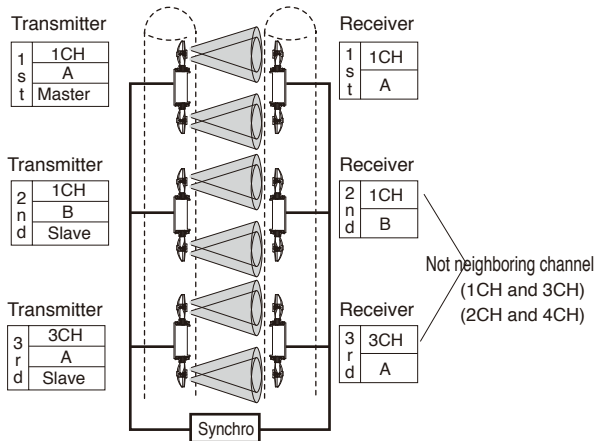

● **Fourth level stacking (Maximum : Four spans)**

- ① Avoid setting the neighboring number of channel in the same direction. (Like 1CH and 2 CH)
- ② In the 3rd and 4th beam, set the same channel and different synchronized timing.

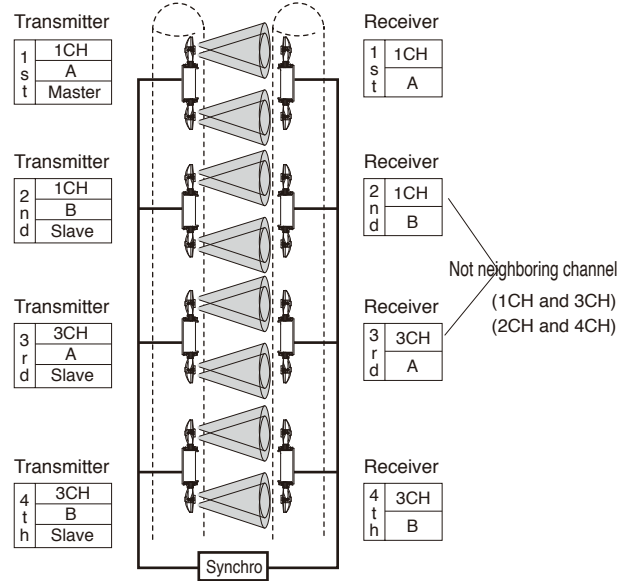

● **Straight line protection**

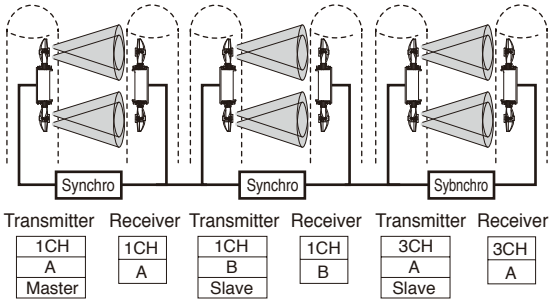

● **2 level straight line protection (Maximum : Eight spans)**

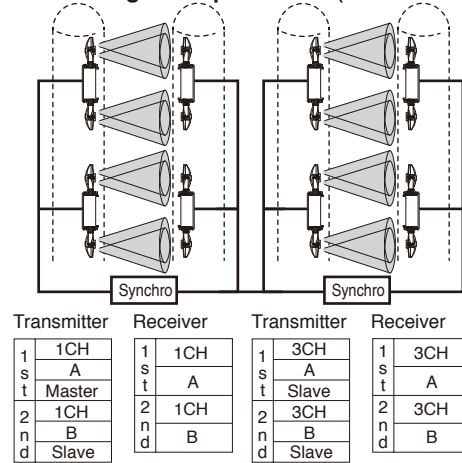

● **Perimeter round protection**

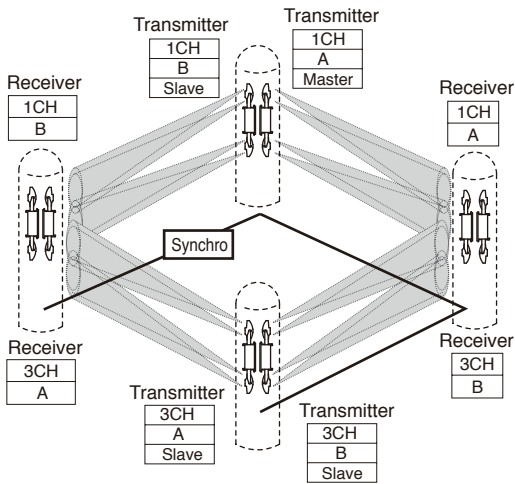

● **2 level external perimeter protection**

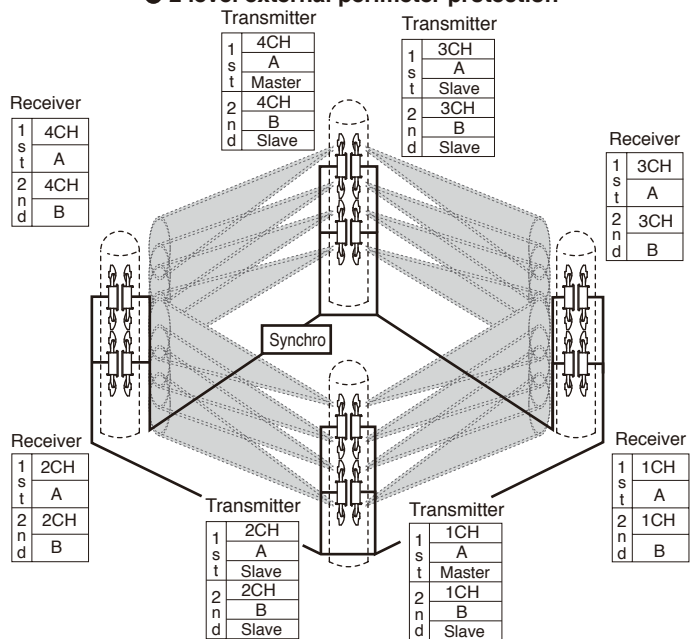

This product adopts the synchronized wire system to allow up to two units having the same channel to be installed in the same direction. If the modulating beam frequency switch function is used together, up to two spans for 6 or 8 level stacking line protection, four spans for the 4-level stacking line protection, eight spans for the 2-level stacking line protection can be easily installed.



# 4 INSTALLATION METHOD

## 4-1 INSTALLATION INTO HOUSING

- Read the instruction manual for your housing carefully, and install the product into the housing correctly.
- Wiring is required based on the sensor installation.  
Refer to "6 WIRING METHOD" for wiring and connection.
- Refer to "9 EXPLANATION OF FUNCTIONS" for switching channels and transmitting beam power.

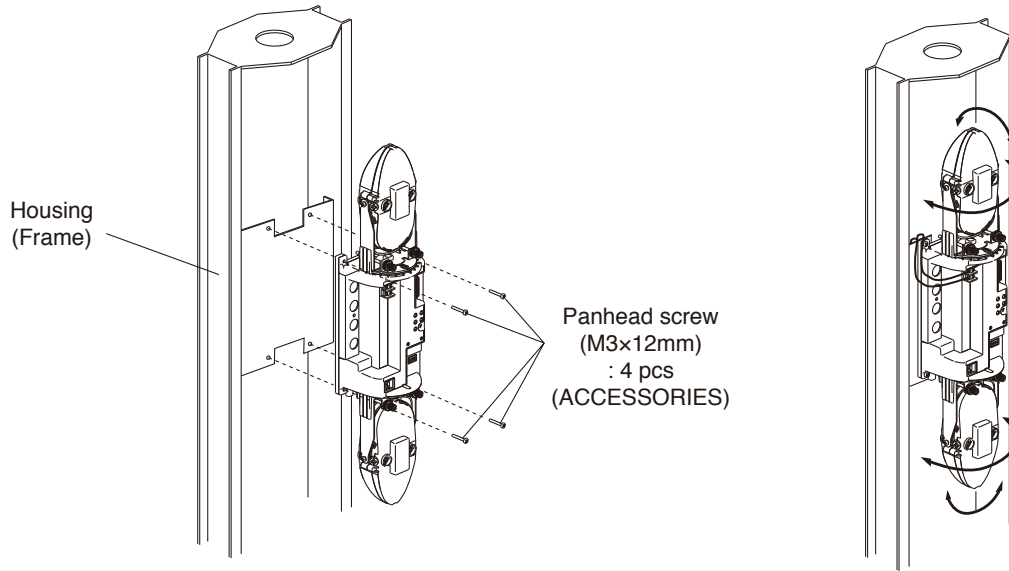

# 5 INITIAL SETTING

## 5-1 MODULATION FREQUENCY CHANGEOVER

\* Installed on the transmitter and the receiver

\* Set the transmitter and the receiver to the same channel.

Factory set : 1CH

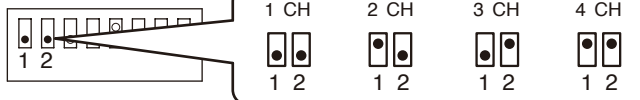

- \* In case of 2 level installation, set the same channel and change the synchronized timing.
- \* In case of more than 3 level installation, change the channel but not neighboring number.

## 5-2 SYNCHRONIZED TIMING

\* Installed on the transmitter and the receiver

In order to avoid cross talk between the same channel, select the different timing setting A or B.

Factory set : A

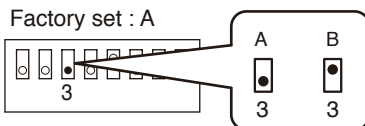

- \* Set the same timing for same transmitter, receiver pair.
- \* In case add one more set in same synchronized wire group, Please set the different timing.

## 5-3 MASTER/SLAVE SELECTION

\* Only installed on the transmitter (Receiver to be slave only)

Master : Output the synchronized signal from synchronized output terminal.

Slave : Transmitter irradiate a beam as setting channel and setting timing according to synchronized input signal from master.

Factory set : Master



- \* Select only one transmitter as Master and others as Slave
- \* One master for up to 7 slaves (Transmitter : 3, Receiver : 4) in one synchronized wire group.

## 5-4 BEAM POWER SELECTION

\* Only installed on the transmitter

\* Select the suitable power according to the installation site (Detection Distance)

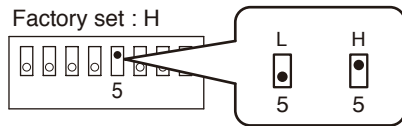

L	H
250ft (75m) or less	250ft (75m) - 330ft (100m)

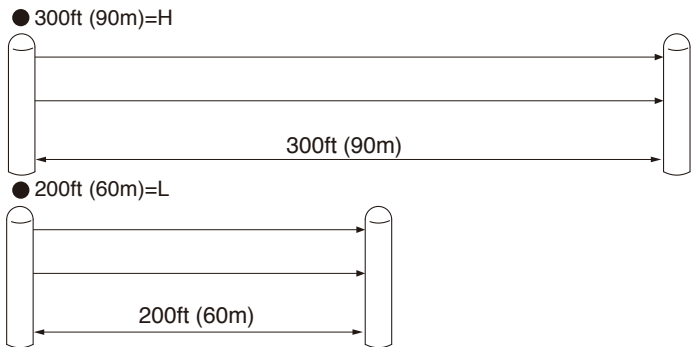

## 5-5 ALARM OUTPUT SWITCH

\* Only installed on the receiver

\* Select N.O. or N.C.

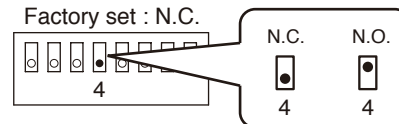

## 5-6 ENVIRONMENTAL OUTPUT SWITCH

\* Only installed on the receiver

\* Select N.O. or N.C.

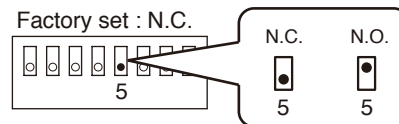

## 5-7 RESPONSE TIME

\* Only installed on the receiver ( AT output )

- In case AT output selected : When either upper or lower beam is shielded (Or-gated) - Response time is set as below.  
When both of upper and lower beam is shielded simultaneously (And-gated) - Response time is 0.05s.
- In case HF output is selected : Signal is issued only when both of upper and lower beam is shielded simultaneously.  
The response time is 0.05s.

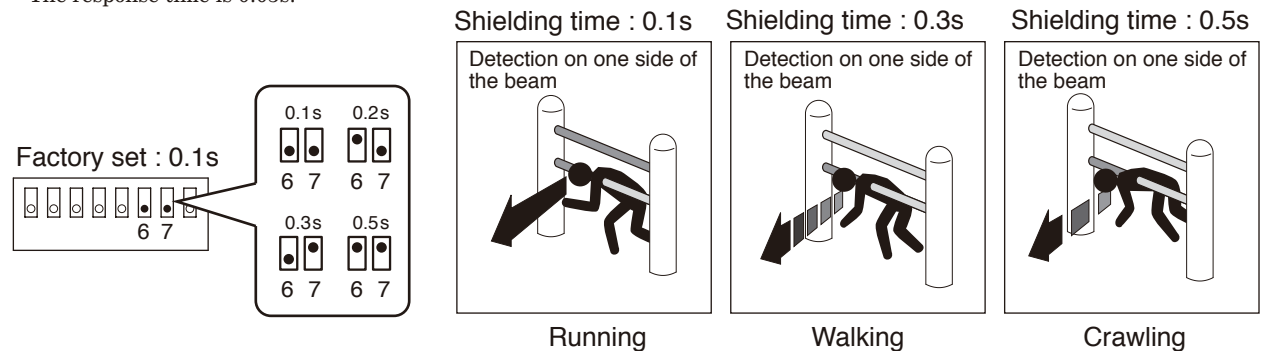

- <<Caution>>
- Detection is not performed when the shielding time is shorter than the detection response time.
  - If there is a possibility that large flying objects (such as birds, newspaper, and cardboard boxes) shield the optical axis, set longer detection response time by one level.  
(Note that a detection response time too much longer could fail to detect intruders.)

## 5-8 SOUND CHECK

\* Only installed on the receiver

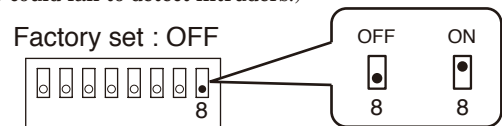

Item	Setting		Details		
	Sound Check Switch	Other settings etc			
Light reception level	ON	Auto Gain Lock switch "OFF" without cover	Light reception level can be checked by the sound tone. The tone pitch becomes higher as the light reception level increases. Also, sounds are not produced when an alarm is being output, when put a cover on, when auto gain lock switch on.		
Auto Gain Lock check sound	—	Approximately 5 sec after Auto Gain Lock switch "ON"	Beep sound	Details	
			"Pi-" (1sec)	The optimum margin of sensitivity has been set.	Pass
			"PiPiPi....." (20sec)	The required margin of sensitivity has not been secured.	Fail
Walk test mode	ON	Approximately 5 minutes after Auto Gain Lock	When performing operation checks, the beep sound is generated in connection with the alarm LED.		

# 6 WIRING METHOD

## 6-1 POSITION AND RATING OF TERMINALS

### <Transmitter>

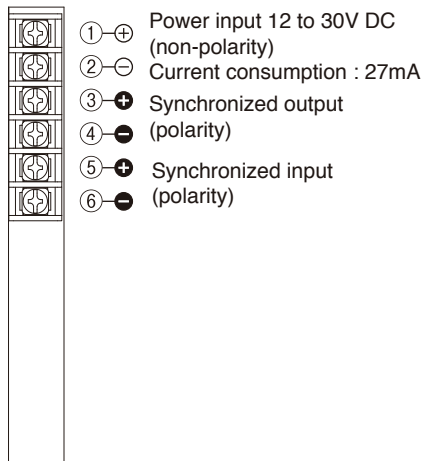

### <Receiver>

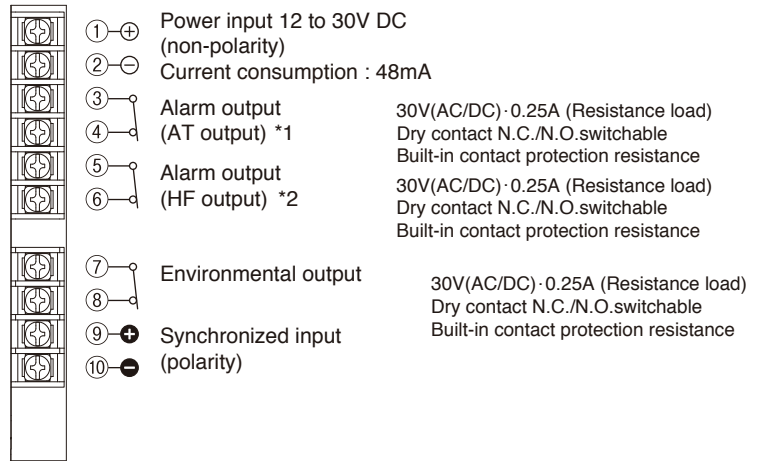

- \*1 In case AT output is selected :  
 When either upper or lower beam is shielded (Or-gated) - Response time is set as selected. When both of upper and lower beam is shielded simultaneously (And-gated) - Response time is 0.05s.
- \*2 In case HF output is selected : Signal is issued only when both of upper and lower beam is shielded simultaneously. The response time is 0.05s.

## 6-2 WIRING DISTANCE

### ● Distance between sensor and power supply

(AWG description)	[ft]	
wire size \ voltage	12V DC	24V DC
AWG20 (Dia.0.8mm)	1,000' ( 300m)	7,100' (2,160m)
AWG18 (Dia.1.0mm)	1,550' ( 473m)	11,000' (3,400m)
AWG17 (Dia.1.1mm)	1,900' ( 580m)	13,500' (4,000m)
AWG16 (Dia.1.25mm)	2,500' ( 750m)	17,000' (5,200m)
AWG15 (Dia.1.4mm)	3,100' ( 950m)	21,500' (6,550m)
AWG14 (Dia.1.6mm)	4,000' (1,200m)	28,500' (8,690m)

### ● Synchronized wiring distance

(AWG description)	[ft]
Wire size	Distance
AWG20 (Dia.0.8mm)	2,850' ( 869m)
AWG18 (Dia.1.0mm) or more	3,300' (1,000m)

\* Maximum 3,300ft(1,000m) and not more.

\* In case two or more sensors connected, divide the distance by the number.

### 6-3 WIRING DISTRIBUTION DIAGRAM (WIRING DIAGRAM)

Note : Connect all transmitters and receivers of the same group by synchronized wiring.  
 Select one transmitter as a master, all the others are as slave.  
 One master may have maximum 7 slaves.

#### ● Single level protection, AT output, Environmental output

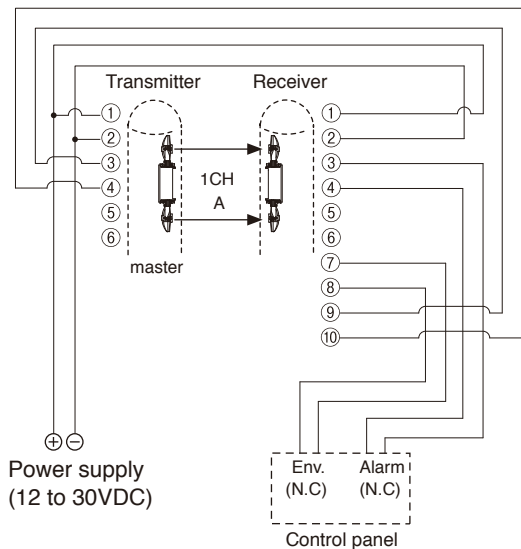

#### ● 2 pairs in a straight line, AT output, Environmental output

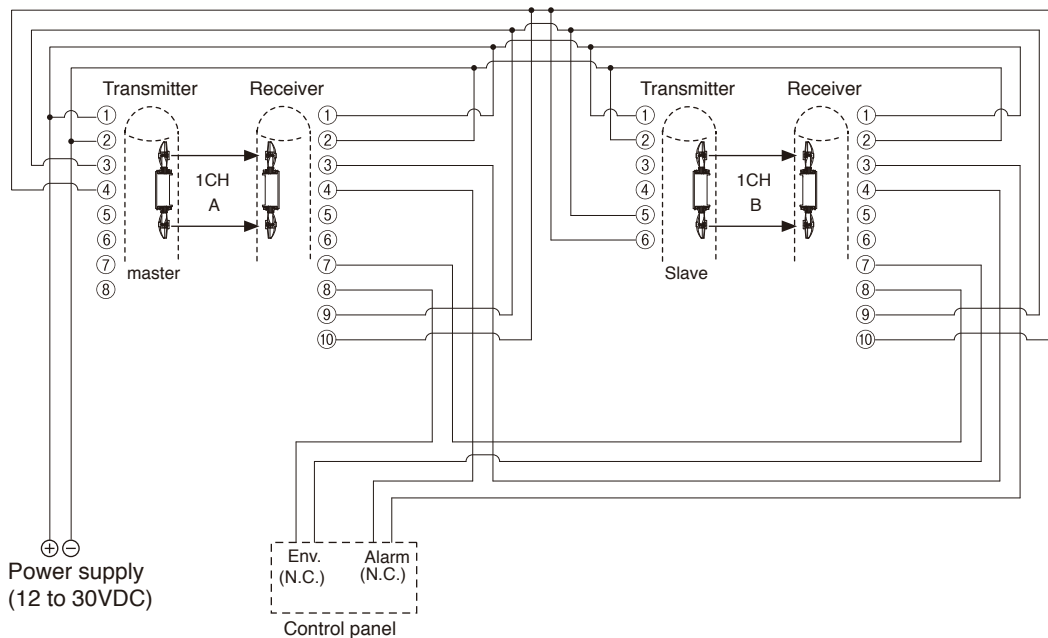

● 2 level protection, 1st pair by HF output, 2nd pair by AT output/HF output swichable

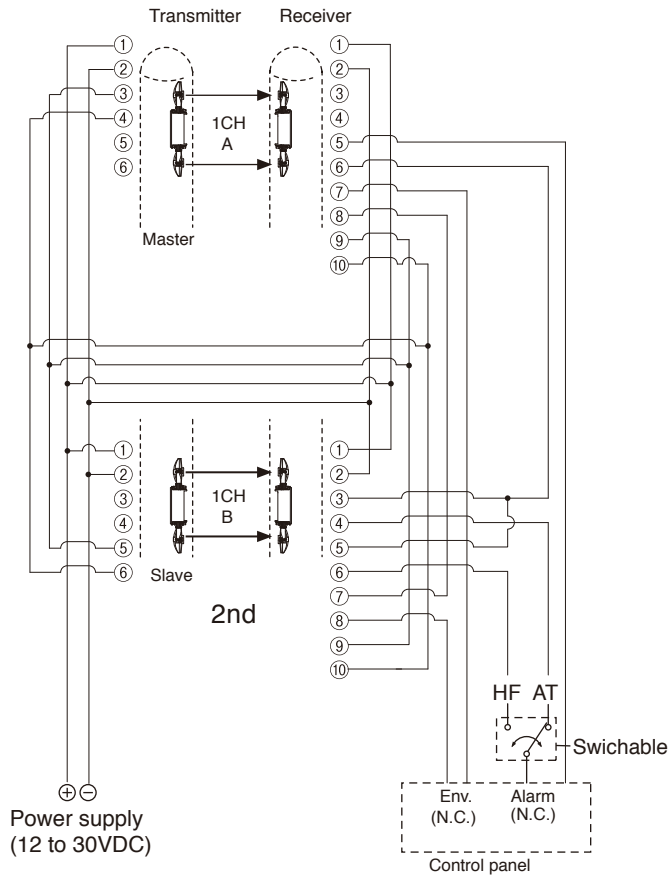

● 2 level protection. 1st pair is PXB-100HF-KH, 2nd pair is PXB-100ATC-KH

- 1) In case PXB-100HF-KH and PXB-100ATC-KH is connected, channel setting cannot be neighbouring or the same number.
- 2) Synchronized wiring cannot be connected to PXB-100HF.

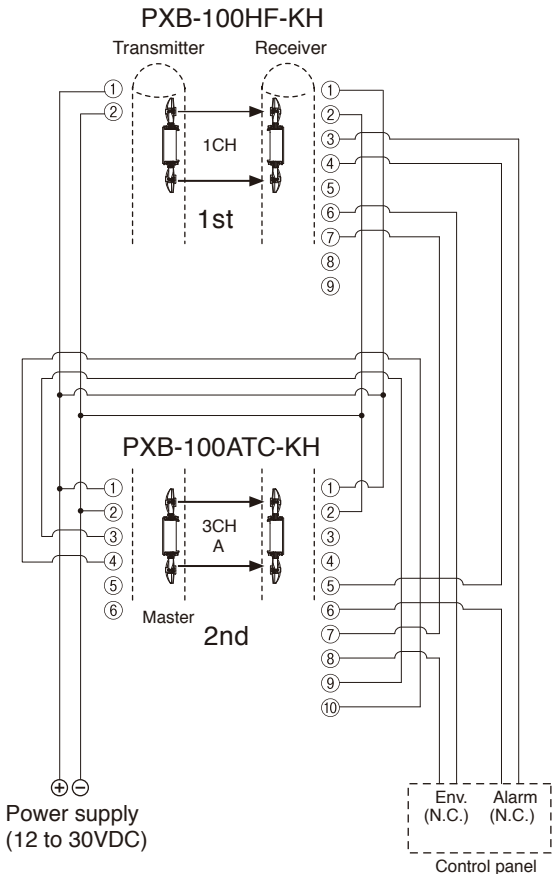

● 4 level protection. AT output.

- 1) Neighbouring channel cannot be set.
- 2) In the same channel, change the synchronized timing.

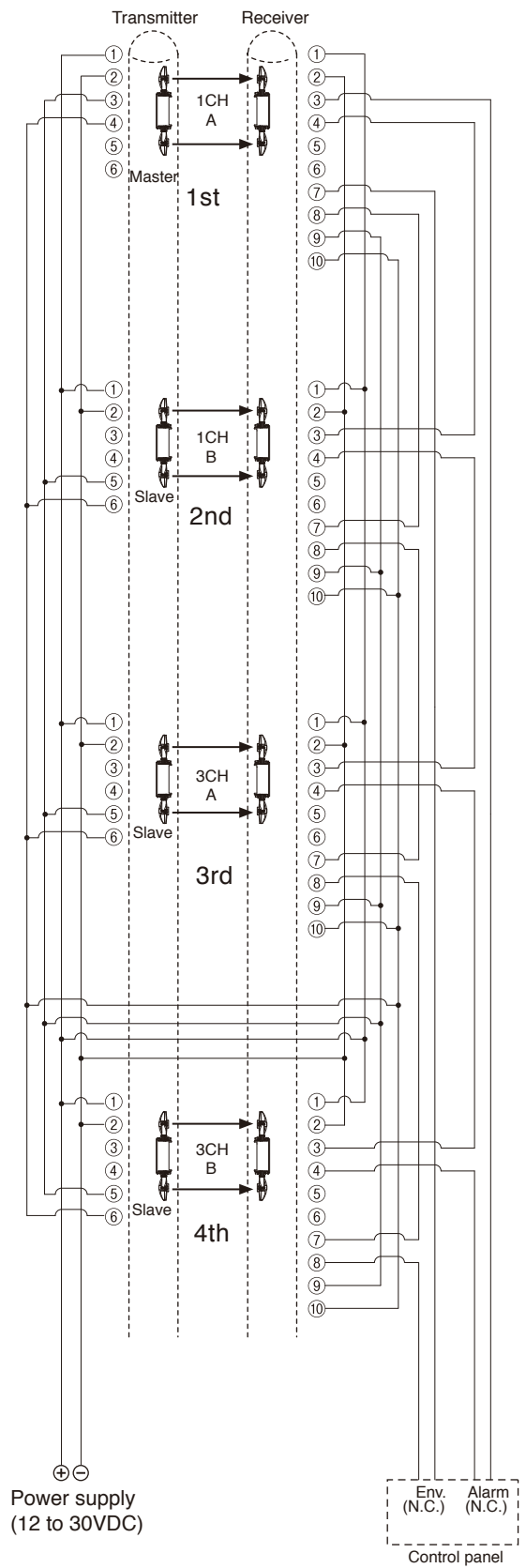

# 7 OPTICAL AXIS ADJUSTMENT

By aligning the optical axis correctly, a protection line with a sufficient margin of sensitivity can be created, reducing the occurrence of malfunction. Always adjust on both upper and lower sections

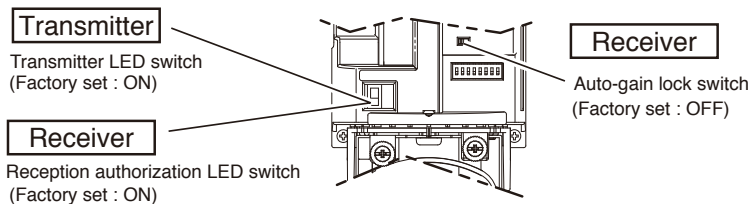

**<<Caution>>** During the optical axis adjustment, make sure to set Auto Gain Lock switch to [OFF], and Transmitter LED switch and Reception authorization LED switch to [ON].

When the optical axis adjustment is completed, set Auto Gain Lock switch to [ON], and Transmitter LED switch and Reception authorization LED switch to [OFF].

## 7-1 NAMES AND FUNCTIONS OF OPTICAL AXIS ADJUSTMENT PARTS

### ● Names of the Optical Unit

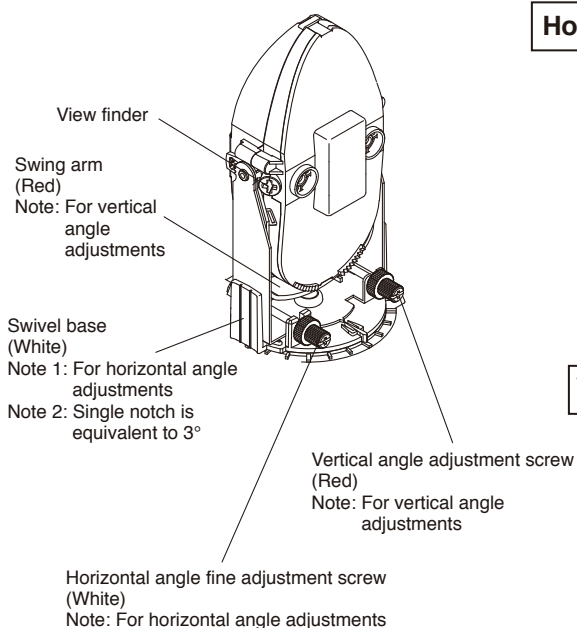

### ● Reflector Section Horizontal/Vertical Angle Adjustment Method

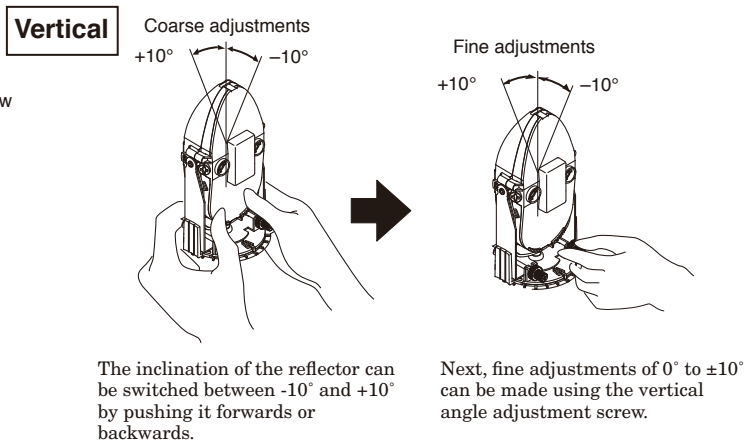
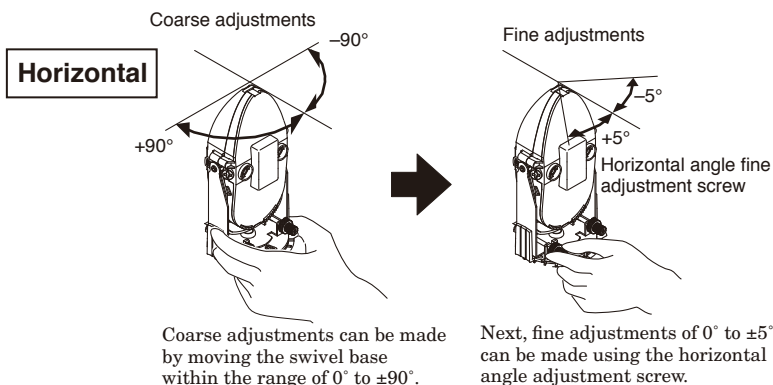

### ● Double Ring Alignment Mechanism Visible from the view finder

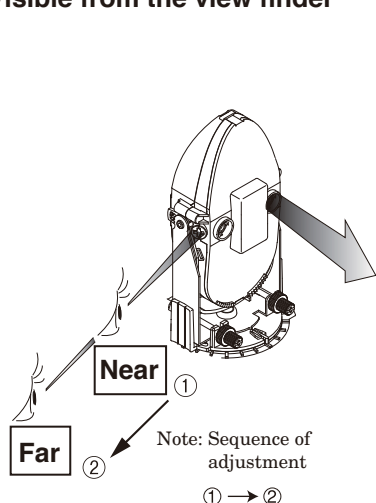

**Near**

When the view finder is looked closely, view appears as the diagram on the right. Adjust the angle so that the target color appears in the center of the ring.

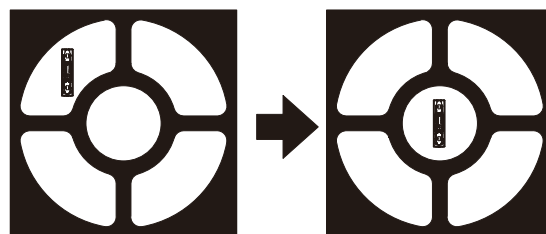

**Far** (The accuracy high)

When the view finder is looked from a distance, the view appears as the diagram on the right. Adjust the angle so that the target color appears in the center of the ring.

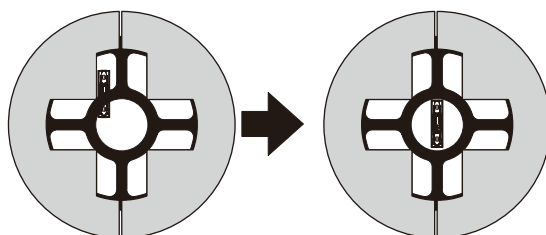

● Names of the Operation Section

Note: This section describes the name and function of each part used during optical axis adjustment.

<Transmitter>

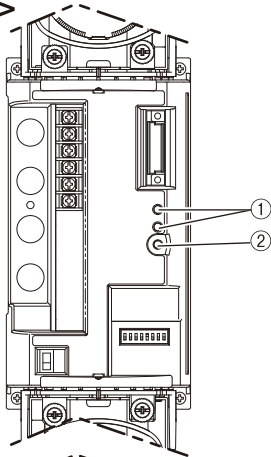

<Transmitter>

- ① Transmission LED: To show which beam operates. When synchronization is unstable, LED blinks alternatively.
- ② Upper/lower changeover switch

**Transmitter**  
 Each time the switch is pressed, the optical unit that transmits the light switches.  
 Transmit from both upper and lower → Only transmit from upper → Only transmit from lower → No transmission

<Receiver>

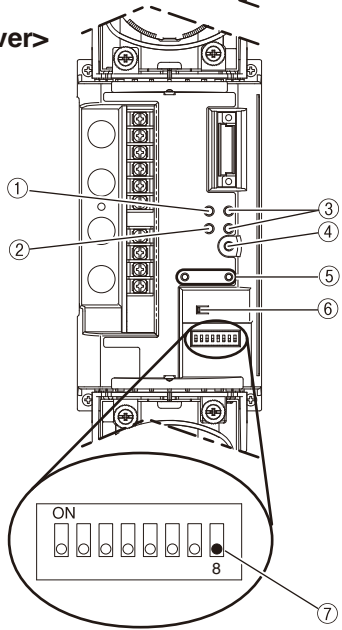

<Receiver>

- ① Alarm LED : Lights on by alarm output
- ② Sensitivity attenuation LED : Lights on when beam reception power is less than certain level.
- ③ Light Reception authorization LED : To show upper or lower beam is receivable or not. When synchronization of the timing is unstable, LED blinks alternatively.

Notice : Attaching the cover, both of upper/lower area receives the beam, LED off.

- ④ Upper/lower changeover switch : To change the status

**Receiver**  
 Each time the switch is pressed, the optical unit that receives the light is switched.  
 Received on both upper/lower → Only received on upper → Only received on lower

- ⑤ Monitor jack: To check the beam reception level
  - \* : Upper beam only authorized : Shows upper reception level
  - Lower beam only authorized : Shows lower reception level
  - \* : Both of upper/lower beam authorized ; Show the reception level of the less one
- ⑥ Auto-gain Lock switch: To maintain the most suitable margin of sensitivity for the protection distance and reduce the occurrence of malfunctions. Please set "OFF" before optical axis adjustment and please set "ON" after complete optical axis adjustment.
- ⑦ Sound check switch: By turning "ON", the beam reception level can be checked by the sound. During walk test, buzzer will be on according to the detection.

**7-2 OPTICAL AXIS ADJUSTMENT USING THE ALIGNMENT MECHANISM**

- 1 Move the swivel base and swing arm so that the opposite device is roughly aligned with the view finder.

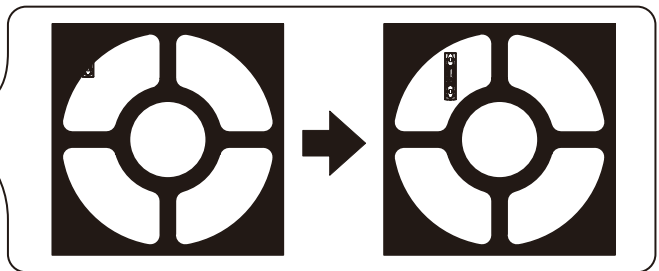
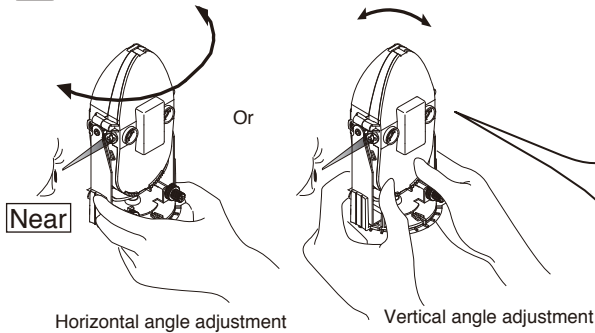

- 2 Look closely through the view finder, and adjust the position so that the sensor of the opposite device is visible at the center of the ring using the horizontal and vertical angle fine adjustment screws.

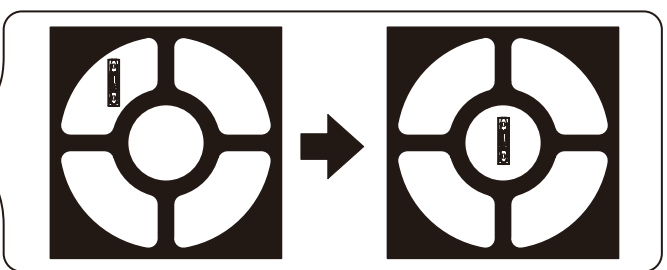
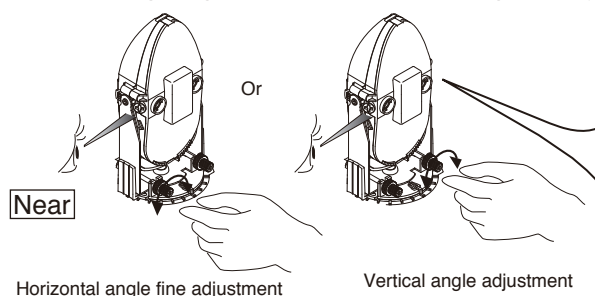

**3** Look through the view finder from a distance, and readjust so that the sensor of the opposite device is visible at the center of the ring using the horizontal and vertical angle fine adjustment screws.

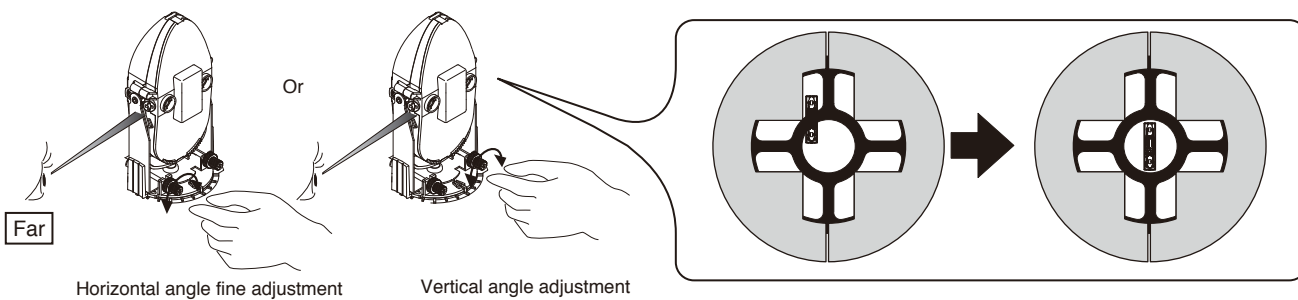

**4** Turn on the power to the transmitter and receiver, check that the LEDs of both the transmitter and receiver are on.

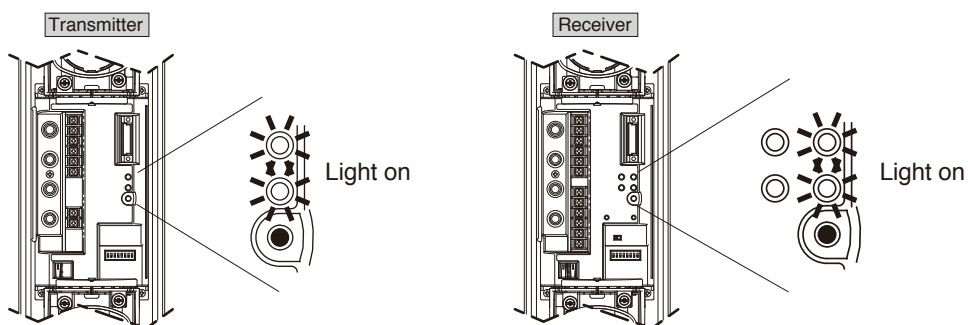

● If the LED of the receiver and transmitter indicates as follows, take an appropriate measure according to the following description.

		Description	Remedy
Receiver		① Improper alignment and insufficient beam power	① Align the beam axis properly
		① Different channel between transmitter and receiver ② The unit is receiving disturbance from other unit	① Set the same channel ② Set the channel as different number
		① Improper sighting	① Align the beam axis properly
		① Wrong synchronazation	① Connect the synchronizing wire properly
Transmitter		① Wrong synchronization (Slave setting sensor only)	① Connect the synchronizing wire properly

: Light on  
 : Flashing  
 : Off



- 5 To improve accuracy of optical axis  
 Perform the procedure of “Optical Axis Adjustment Using the Sound Check”, “Optical Axis Fine Adjustment Using the Monitor Output Voltage”, or “Optical Axis Fine Adjustment Using the Alignment Wireless Checker”.

### Optical Axis Fine Adjustment Using the Sound Check

- The sound check function indicates the light reception level by using high and low pitch tones.
- The sound check function is only installed on the receiver.

#### <<Caution>>

First, check only the transmission on the upper level and reception on the upper level, and then check only the transmission on the lower level and reception on the lower level.

(When the light can be received on both the upper and lower levels, the beep sound at the total light reception level of the upper and lower levels are generated.)

1. Turn the sound check switch on the receiver to the ON position.

When the optical axis is roughly aligned, the beep sound can be heard.

The optical axis is greatly misaligned if no sound can be heard.

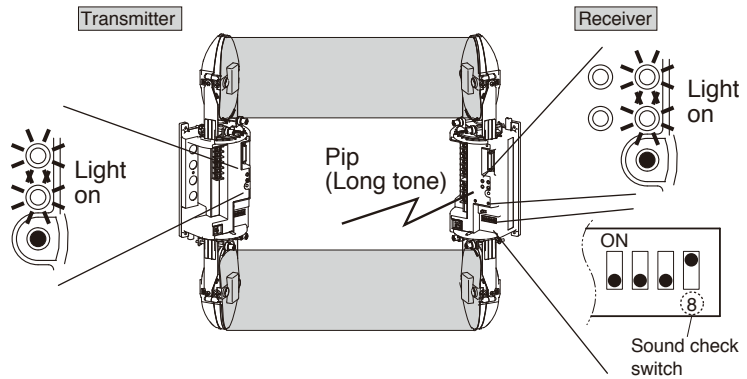
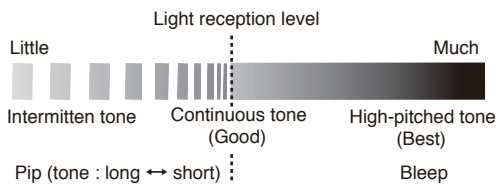

2. Fine adjust the upper level optical axis.

- (1) Press the upper/lower changeover switch on the transmitter to select [Only transmit from upper].
- (2) Press the upper/lower changeover switch on the receiver to select [Reception authorization on upper only].
- (3) Turn the adjustment screw to fine adjust until the tone reaches the highest pitch.  
(Adjust both the transmitter and receiver.)

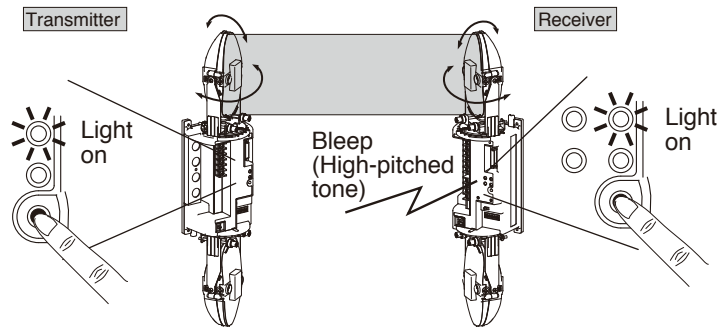

3. Fine adjust the lower level optical axis.

- (1) Press the upper/lower changeover switch on the transmitter to select [Only transmit from lower].
- (2) Press the upper/lower changeover switch on the receiver to select [Reception authorization on lower only].
- (3) Turn the adjustment screw to fine adjust until the tone reaches the highest pitch.  
(Adjust both the transmitter and receiver.)

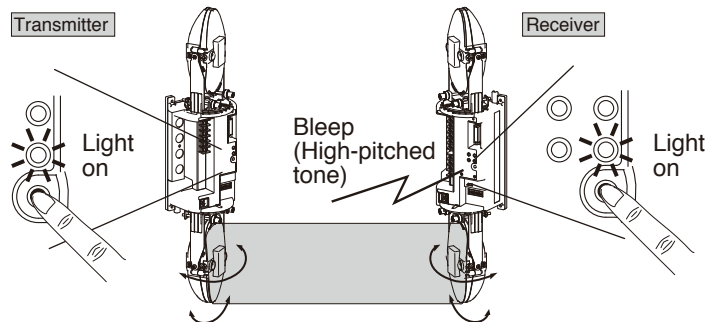

4. Check if the light from another transmitter enters the receiver.

- (1) Press the upper/lower changeover switch on the transmitter to select [No transmission].
- (2) Press the upper/lower changeover switch on the receiver to select [Reception authorized for both upper and lower].
- (3) Check that the alarm LED lights up when the receiver outputs an alarm signal, and that the sensitivity attenuation LED also lights up.

- If no alarm is activated or the sensitivity attenuation LED is not lit

When using multi-level protection, there may be some effects of other photoelectric beam sensors. In such case, readjust the other photoelectric beam sensors to reduce the effects to the minimum possible.

In addition, check that an appropriate channel is set.

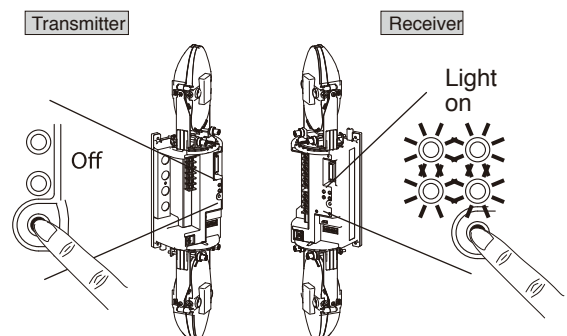

## Optical Axis fine Adjustment Using the Monitor Output Voltage

- Accurate adjustments of the optical axis can be achieved by checking the light reception level value using the voltage of the monitor output.

### <<Caution>>

First, check only the transmission on the upper level and reception on the upper level, and then check only the transmission on the lower level and reception on the lower level.

(The values are not displayed correctly when the light can be received for both the upper and lower levels.)

See the following table for the monitor output voltage.

Monitor Output Voltage	Light Sensitivity
More than 2.2 V DC	Best
2.0 to 2.2V DC	Good
Less than 2.0V DC	Poor, re-adjust

1. Insert a commercially available tester into the monitor jack on the receiver.

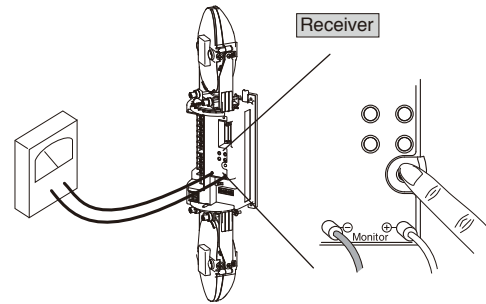

### <<Caution>>

The monitor jack is polarized.

Check the polarity of the tester pin before inserting it.

Use a tester with an internal resistance of over 100 kΩ.

2. Fine adjust the upper level optical axis.

- (1) Press the upper/lower changeover switch on the transmitter to select [Only transmit from upper].
- (2) Press the upper/lower changeover switch on the receiver to select [Reception authorization on upper only].
- (3) Turn the adjustment screw to fine adjust until the monitor output voltage reaches the highest value.  
(Adjust both the transmitter and receiver.)

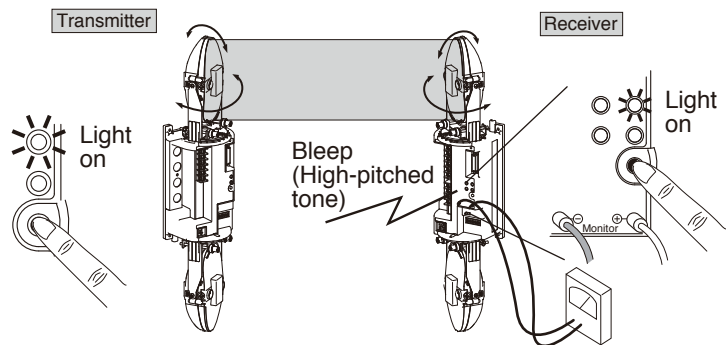

3. Fine adjust the lower level optical axis.

- (1) Press the upper/lower changeover switch on the transmitter to select [Only transmit from lower].
- (2) Press the upper/lower changeover switch on the receiver to select [Reception authorization on lower only].
- (3) Turn the adjustment screw to fine adjust until the monitor output voltage reaches the highest value.  
(Adjust both the transmitter and receiver.)

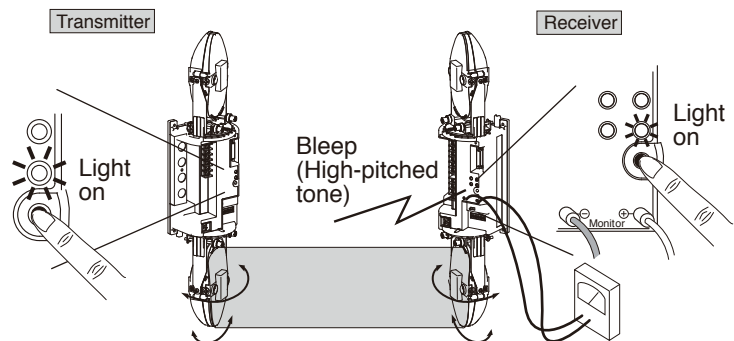

4. Check if the light from another transmitter enters the receiver.

- (1) Press the upper/lower changeover switch on the transmitter to select [No transmission].
- (2) Press the upper/lower changeover switch on the receiver to select [Reception authorized for both upper and lower].
- (3) Check that the alarm LED lights up when the receiver outputs an alarm signal, and that the sensitivity attenuation LED also lights up. Also check the monitor output voltage.

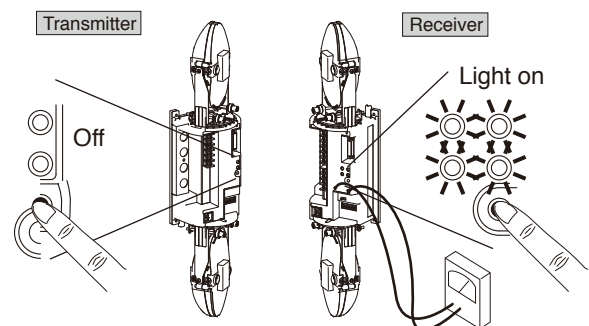

- If no alarm is activated or the sensitivity attenuation LED is not lit

When using multi-level protection, the monitor output voltage may become close to "1 V" due to effects of other photoelectric beam sensors. In such case, readjust the other photoelectric beam sensors to reduce the effects to the minimum possible. In addition, check that an appropriate channel is set.

## Optical Axis Fine Adjustment Using the Alignment Wireless Checker:ER-02(Sold Separately)

- Accurate adjustments of the optical axis can be achieved by checking the light reception level value using the voltage of the monitor output.
  - As the light reception level value can also be checked using the voltage on the transmitter, more accurate adjustments of the optical axis can be achieved.
- Using the alignment wireless checker enables easy and accurate beam alignment.  
Providing sufficient margin of sensitivity increases resistance to the dense fog, snow, and heavy rain, which makes it possible to construct a highly reliable intrusion alarm system.

Note: For detailed operation procedure of the alignment wireless checker, refer to the instruction manual for the alignment wireless checker ER-02.

# 8 OPERATION CHECK

Be sure to perform an operation check after the optical axis adjustment.

**1** Set Transmitter LED switch of the transmitter to [OFF] and mount the cover (housing).  
When Transmitter LED switch is set to [OFF], the LED light turns off, but the upper and lower beams are transmitted.

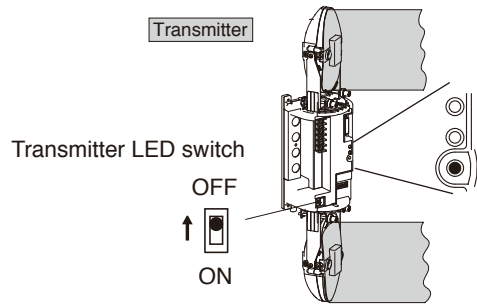

**2** After the optical adjustment is completed, set Auto Gain Lock switch to [ON] under the light beam reception condition, and wait for approximately 5 seconds.  
During this period, do not shield the optical axis.  
A one-time short beep sound [Pi-] shows that the auto gain lock is completed correctly.  
(After the auto gain lock, the upper and lower LEDs light off.)  
Set Reception authorization LED switch of the receiver to [OFF].

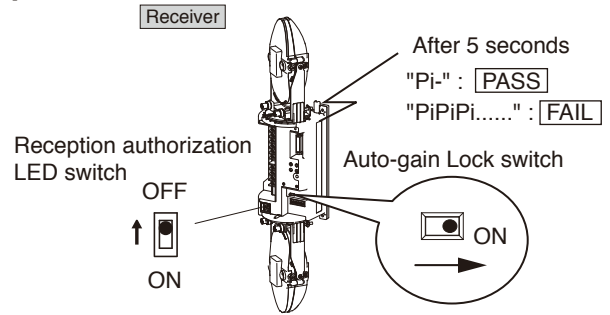

After the auto gain lock is completed correctly, the walk test mode is activated for 5 minutes regardless of whether the cover is mounted or not. During the walk test mode, the beep sound is generated when the alarm LED lights on by the alarm output. After approximately 5 minutes has elapsed, the walk test mode ends. Even if Auto Gain Lock switch is not set to [ON], set Reception authorization LED switch to [OFF] activate the walk test mode for 5 minutes.

**<<Caution>>**

- ① The intermittent beep sound like “PiPiPi.....” shows that the beam reception volume is not enough. In this case, the LED on the side of the insufficient reception volume blinks. Set Auto Gain Lock switch to [OFF], and adjust the optical axis again.
- ② In the multi-level protection, when the light enters from other units than the opposing transmitter, turn off the power of the other transmitter to stop transmitting the light beam, then set Auto Gain Lock switch to [ON].

**3** Obstruct the sensor beams near the sensor or the center of the detection line and check that an alarm can be output correctly.

If the sound check switch is set to ON, after the auto gain lock has been completed normally, the walk test mode is activated for 5 minutes. The beep sound is generated in synchronization with the alarm output.  
The alarm LED lights up according to the alarm output.

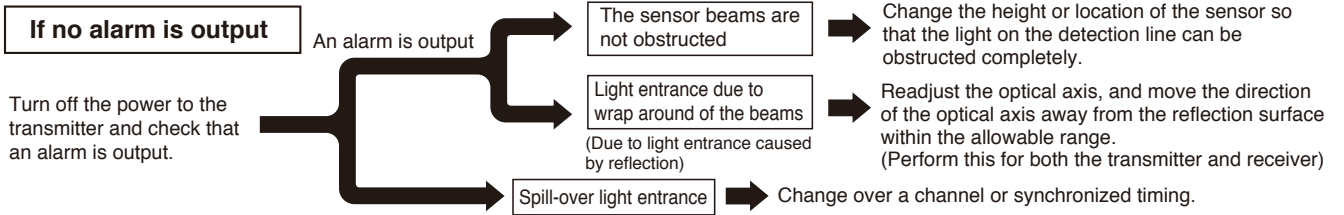
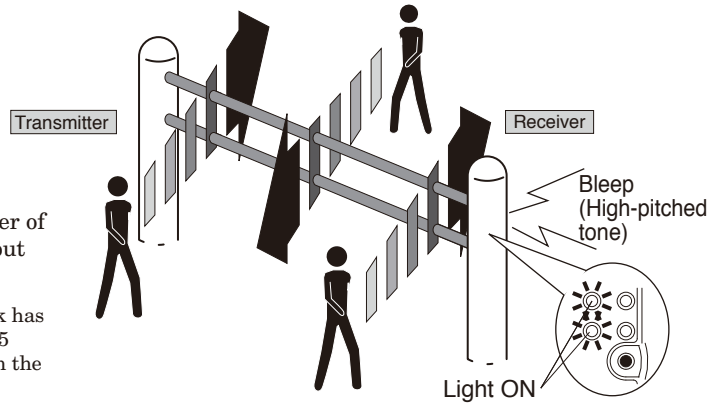

**Light entrance due to beam wraparound**

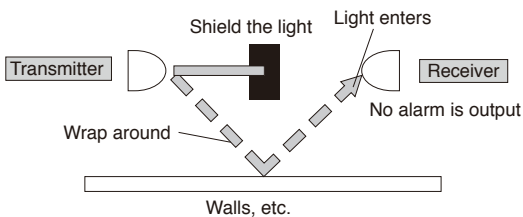

**Spill-over light entrance**

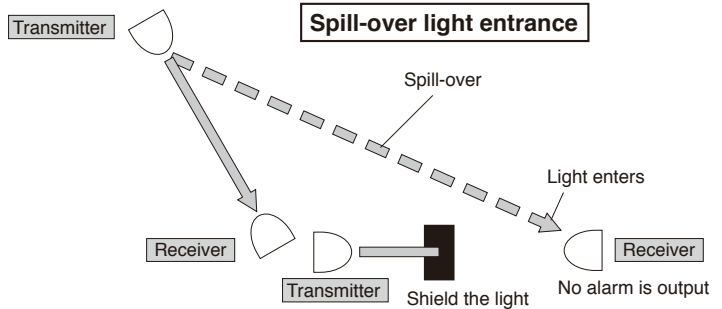

**4** In using the environmental output, confirm that the environmental output is generated when the optical axes in both the upper and lower sections are shielded for 20 seconds or more.

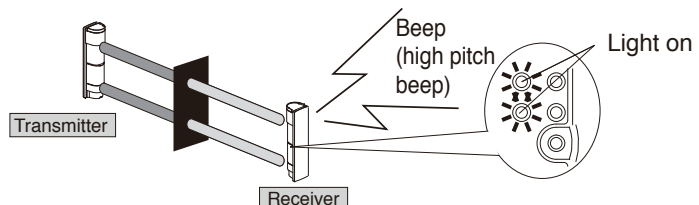

# 9 EXPLANATION OF FUNCTIONS

This section describes the detailed information of the functions that appear in this instruction manual. Set each function according to the description below.

## 9-1 AUTO GAIN LOCK FUNCTION \* Only installed on the receiver

- Provided the units are used within the maximum rated protection distance, this function is used to automatically set the optimum margin of sensitivity for the receiver in any protection distance

### <<Caution>>

Please set "OFF" during adjust optical axis.

Please set "ON" and then put cover on after complete optical axis adjustment.

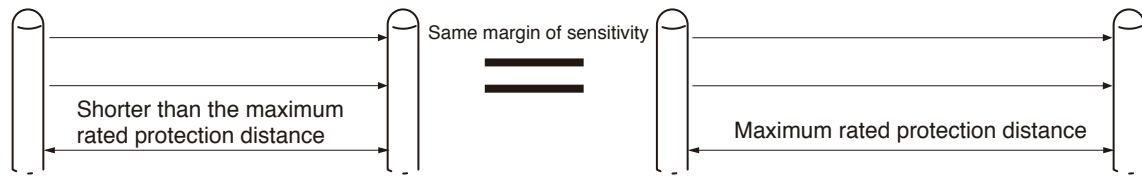

Auto Gain Lock switch  
(Factory set : OFF)



OFF

ON

### Checking the conditions

After 5 seconds when Auto Gain Lock switch is "ON", the beep sounds to show the conditions.



: Light on

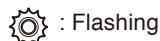

: Flashing



: Off

Beep	Light reception authorization LED	Results	Cause	Remedy
"Pi-" (1sec)	1 sec	PASS		
"PiPiPi...." (20sec)	: Reception level of the upper beam is not enough : Reception level of the lower beam is not enough : Reception level of upper/lower beam is not enough	FAIL	① When switching "ON" the Auto Gain Lock switch, the beam was interrupted. ② Improper beam alignment.	① Remove the interruption and retry switch "ON" Auto Gain Lock. ② Re-align the optical axis adjustment.

## 9-2 UPPER/LOWER CHANGEOVER FUNCTION \* Available on transmitter and receiver

- This function allows the upper and lower sensors to be switched "ON" and "OFF".

\* The sensors switch as shown in the diagram below when the upper/lower changeover switch is pressed.

Transmission/reception authorization LED  
(Different displays for upper and lower)

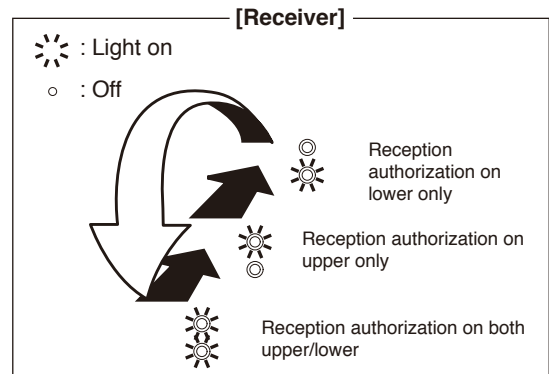
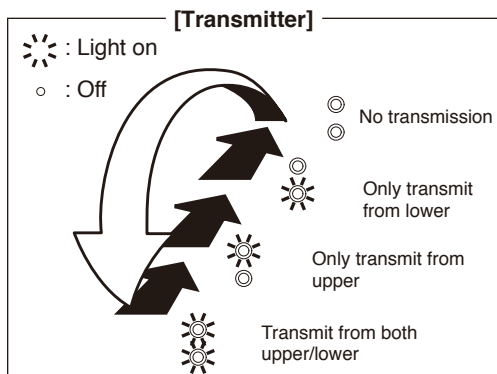
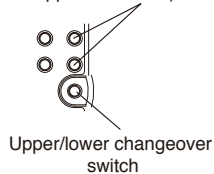

## 9-3 LED LIGHT TURN-OFF FUNCTION \* Available on transmitter and receiver

- This function is used to light on/off Transmitter LED and Reception authorization LED. Also, when the LED in the receiver lights [OFF], the attenuation correction is conducted for the cover.

- ① After the LED switches are turned [OFF], the LEDs light off, but the light beam is transmitted and received on both the upper and lower sections.
- ② Reception authorization LED also lights off when Auto Gain Lock switch in the receiver is set to [ON], but set Reception authorization LED switch to [OFF] during operation.

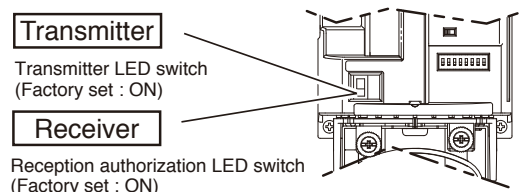

## 9-4 PROGRAMMABLE AGC(AUTO GAIN CONTROL) FUNCTION \* Only installed on the receiver

- When the beam power decreases in harsh environment by dense fog, heavy rain. This is a function to increase the receiving sensitivity temporarily and to stabilize operation. The receiver adjusts this function to start or to stop automatically depending on beam power from transmitter.
- When the Programmable AGC works, the beam power level which already decreased recovers to certain power level and is maintained.
- When the Programmable AGC works, the environmental signal is issued, and it is continuing to monitoring the beam power level while the environmental signal is issued.
- When either upper beam or lower beam power decrease, the Programmable AGC works and the environmental signal is issued.
- When both upper beam and lower beam power recover to stable level, the Programmable AGC function and the environmental output stop automatically.
- In order to operate the Programmable AGC function correctly, it is necessary to set up "Auto Gain Lock" function correctly.
- The margin of sensitivity is maintained even if there is a sudden worsening in weather conditions.

## 9-5 EXTERNAL ENVIRONMENT DIAGNOSTIC FUNCTION \* Only installed on the receiver

- This function outputs a notification before a warning is output as an environmental output when such impairments as fog or heavy rain occur.  
If such impairments continues for 20sec, an environmental output is issued.

### <<Caution>>

Even if the beam power recover immediately, an environmental output is issued for at least 5sec.

## 9-6 ALARM LED \* Only installed on the receiver

- LED is on according to signal output (Both AT output, HF output)

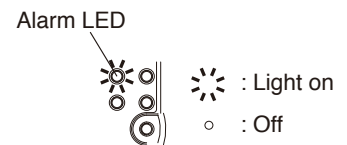

## 9-7 LIGHT SENSITIVITY SIGNAL FUNCTION \* Only installed on the receiver

- This lights when there is an insufficient level of infrared light received by the receiver, and it is judged that there is insufficient margin of sensitivity, and to inform you that adjustments are required.

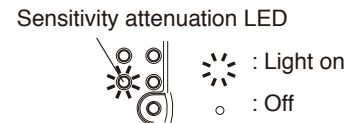

## 9-8 FUNCTION SETTING CHECK

- Check the various functions according to the table as below

Whether to set on transmitter or receiver	Setting	Setting details			
Both transmitter and receiver	Modulation frequency	<input type="checkbox"/> 1CH	<input type="checkbox"/> 2CH	<input type="checkbox"/> 3CH	<input type="checkbox"/> 4CH
	Synchronized timing	<input type="checkbox"/> A	<input type="checkbox"/> B		
Transmitter only	Master or slave	<input type="checkbox"/> Master	<input type="checkbox"/> Slave		
	Beam power	<input type="checkbox"/> H	<input type="checkbox"/> L		
Receiver only	Signal output	<input type="checkbox"/> N.O.	<input type="checkbox"/> N.C.		
	Environmental output	<input type="checkbox"/> N.O.	<input type="checkbox"/> N.C.		
	Response time (AT output)	<input type="checkbox"/> 0.1s	<input type="checkbox"/> 0.2s	<input type="checkbox"/> 0.3s	<input type="checkbox"/> 0.5s
	Sound check	<input type="checkbox"/> ON	<input type="checkbox"/> OFF		

## 9-9 ALIGNMENT WIRELESS CHECKER CONNECTION FUNCTION \* Installed on the transmitter and the receiver

- By connecting an alignment wireless checker (sold separately), it is possible to transmit data bidirectionally, check the monitor output voltage of the receiver from the transmitter, and simultaneously switch the optical axis light obstruction.

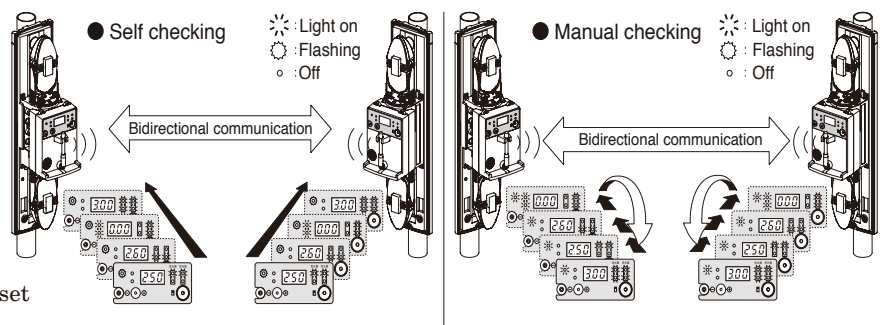

### <<Caution>>

When using the wireless checker, please set Auto Gain Lock switch "OFF" certainly.

\* Alignment wireless checker : ER-02

# 10 TROUBLESHOOTING

(If the device does not operate properly)

Check the device by referring to the table below. If you cannot restore the device to a normal condition after the check, contact the place of purchase or TAKEX.

Status	Cause	Remedy
Transmitter LED does not light (cover is open)	(1) Power is not on (2) Poor wiring or breaking of wire, short (3) Transmitter is set to [Do not transmit] (4) LED light turn-off switch is [OFF]	(1) Connect the power source (2) Check again (3) Press the upper/lower changeover switch (4) Change over to [ON]
Reception authorization LED does not light on (when the cover is open)	(1) Power is not on (2) Poor wiring or breaking of wire, short (3) Auto Gain Lock switch is ON (4) Set Auto Gain Lock switch to OFF	(1) Connect the power source (2) Check again (3) LED light turn-off switch is [OFF] (4) Change over to [ON]
Alarm LED does not light even if the infrared beam is obstructed	(1) Power is not on (2) Poor wiring or breaking of wire, short (3) Photoelectric beam is reflected by some object and entering the receiver (4) The sensor beams are not obstructed (5) Sensor beam is obstructed for less time than the detection response time setting in the receiver	(1) Connect the power source (2) Check again (3) Remove the reflecting object, or change the installation location or optical axis direction (4) Shield the light (5) Shorten the detection response time
Alarm LED does not go out (Alarm output does not stop)	(1) Alignment (optical axis) is not aligned correctly (2) There is an obstruction between the transmitter and receiver (3) Transmitter/receiver cover or reflection section is dirty (4) Frequency channel settings on the transmitter and receiver do not match (5) The synchronized timing does not match on the transmitter and receiver.	(1) Perform angle adjustment again and set the gain lock (2) Remove the object (3) Clean using a soft cloth (4) Readjust the frequency channels so they are the same (5) Match the synchronized timing.
Transmitter LED and Reception authorization LED on the upper and lower sections blink alternately. (The alarm output does not stop.)	(1) The synchronized wire is not correctly connected. (2) The master is not set.	(1) Connect the synchronized wire correctly. (2) Set only one unit as a master.
Continually activated	(1) Poor wiring connection (2) Change of supply voltage (3) Obstruction between transmitter and receiver (objects such as branches that move with the wind) (4) The wiring of the transmitter/receiver is located nearby a power line (5) Unstable sensor installation (6) Transmitter/receiver cover or reflection section is dirty (7) Improper alignment (optical axis) (8) A large bird or cat may obstruct the beams (9) Beam power switch is set to L, which does not keep enough margin of sensitivity	(1) Check again (2) Stabilize the supply voltage (3) Remove the object (4) Change the wiring route (5) Fix in a stable location (6) Clean using a soft cloth (7) Perform optical axis adjustment again, set the gain lock and secure the margin of sensitivity (8) Set the response time to be slightly longer (however, this is not possible if there is a possibility that an intruder could run through at top speed) (9) Set the beam power switch to H, remove the receiver cover and set the gain lock again

## DAILY INSPECTIONS

- To clean the device, use a soft, wet cloth and then wipe off any water drops.  
If the device is particularly dirty, dip the soft cloth in water that includes a weak neutral detergent.  
Wipe the device gently with the cloth, then wipe off any detergent that remains.  
Do not use substances such as thinner or benzene. (The plastic parts may deform, discolor or change their properties.)
- Perform operation checks on a regular weekly basis.

# 11 SPECIFICATIONS

Model	PXB-100ATC-KH
Detection system	Near infrared pulsed beam interruption system (Anti-crawling, Anti-corrosion)
Infrared beam	Double modulation pulsed beam by LED
Protection distance	Outdoor 330' (100m) or less
Response time	AT output : 0.05sec by upper/lower level simultaneous interruption 0.1/0.2/0.3/0.5sec by either level interruption HF output : 0.05sec by upper/lower level simultaneous interruption
Power supply	12 to 30V DC (Non-polarity)
Current consumption	Transmitter : 27mA Receiver : 48mA
Alarm output	Dry contact relay output N.O./N.C. selectable Contact action : Interruption time (Min.2sec.) Contact capacity : 30V (AC/DC) 0.25A (resistive load) Protective resistor
Environmental output	Dry contact relay output N.O./N.C. selectable Action : Activated when weather condition gets worse (Min.5sec.) Contact capacity : 30V (AC/DC) 0.25A (resistive load) Protective resistor
Alarm LED	Red LED (Receiver) ON : when an alarm is initiated
Attenuation LED	Red LED (Receiver) ON : when beam is attenuated
Ambient temperature range	-31°F to +151°F (-35°C to +66°C)
Beam adjustment	Horizontal: ±90°, Vertical: ±20°
Functions	Modulated beam frequency selection, Tone indicator, Environmental module, Beam power selection, Transmitting power adjustment, Programmed AGC, Auto-gain lock function, Monitor Jack, Tamper, Response time adjustment, Upper/lower beam switch Wireless checker, LED light turn-off function
Mounting positions	Inside the housing
Wiring	Terminals
Weight	Transmitter : 12.6oz (360g) Receiver : 15.8oz (450g)

# 12 EXTERNAL DIMENSIONS

Unit: inch (mm)

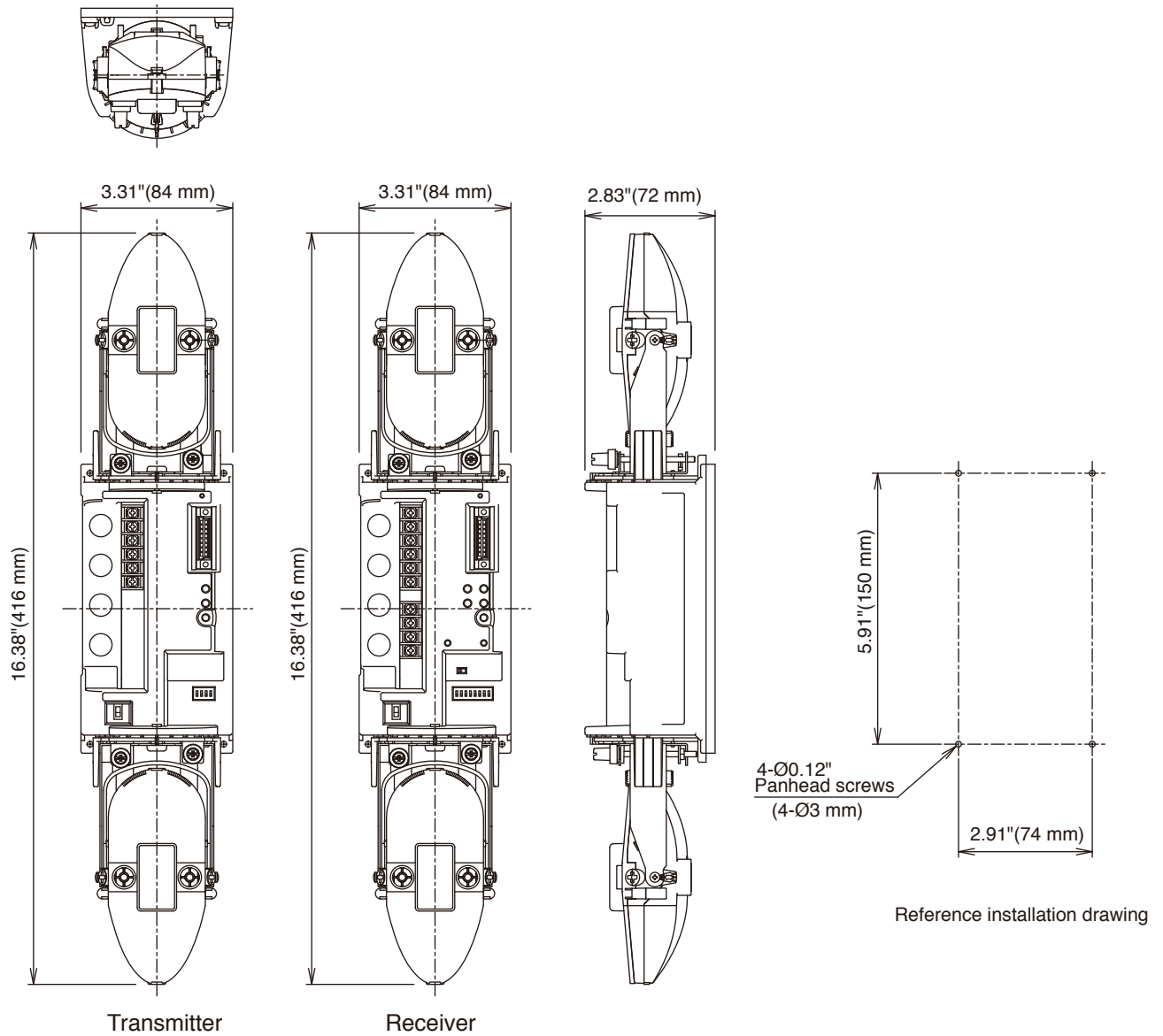

■ Options : Alignment wireless checker : ER-02

**Limited Warranty :**

TAKEX products are warranted to be free from defects in material and workmanship for 12 months from original date of shipment. Our warranty does not cover damage or failure caused by natural disasters, abuse, misuse, abnormal usage, faulty installation, improper maintenance or any repairs other than those provided by TAKEX. All implied warranties with respect to TAKEX, including implied warranties for merchantability and implied warranties for fitness, are limited in duration to 12 months from original date of shipment. During the Warranty Period, TAKEX will repair or replace, at its sole option, free of charge, any defective parts returned prepaid. Please provide the model number of the products, original date of shipment and nature of difficulty being experienced. There will be charges rendered for product repairs made after our Warranty Period has expired.



In Japan

**Takenaka Engineering Co., Ltd.**  
83-1, Gojo-sotokan, Higashino,  
Yamashina-ku, Kyoto 607-8156, Japan  
Tel : 81-75-501-6651  
Fax : 81-75-593-3816  
<http://www.takex-eng.co.jp/>

In the U.S.

**Takex America Inc.**  
151, San Zeno WAY  
Sunnyvale, CA 94086, USA  
Tel : 408-747-0100  
Fax : 408-734-1100  
<http://www.takex.com>

In Australia

**Takex America Inc.**  
4/15 Howleys Road, Notting Hill,  
VIC, 3168  
Tel : +61 (03) 9544-2477  
Fax : +61 (03) 9543-2342

In the U.K.

**Takex Europe Ltd.**  
Aviary Court, Wade Road,  
Basingstoke, Hampshire, RG24 8PE, U.K.  
Tel : (+44) 01256-475555  
Fax : (+44) 01256-466268  
<http://www.takex.com>